

# Rosemount™ 644 Temperature Transmitter



## The most versatile temperature transmitter

Reduce complexity and simplify the day-to-day operations of your diverse temperature applications with the versatile Rosemount 644 family of temperature transmitters. Make better decisions for your process with the new and easy-to-use Rosemount 644 Temperature Transmitter capabilities, including: diagnostics, safety certification, integral transient protection, and display options.

## Features and benefits

### Fulfill your needs within one model family with a customizable transmitter design



- DIN head and field mount form factors
- 4–20 mA/HART® with Selectable Revision 5 and 7, FOUNDATION™ Fieldbus, or PROFIBUS® PA protocol support
- Safety integrity level (SIL) 3 capable: IEC 61508 certified by an accredited third-party agency for use in safety instrumented systems up to SIL 3 (minimum requirement of single use [1oo1] for SIL 2 and redundant use [1oo2] for SIL 3)
- Enhanced display with local operator interface (LOI)
- LCD display
- Integral transient protection
- Enhanced accuracy and stability
- Transmitter-sensor matching with Callendar-Van Dusen constants
- Variety of enclosures

### Access information when you need it with asset tags

Newly shipped devices include a unique QR code asset tag that enables you to access serialized information directly from the device. With this capability, you can:

- Access device drawings, diagrams, technical documentation, and troubleshooting information in your MyEmerson account.
- Improve mean time to repair and maintain efficiency.
- Ensure confidence that you have located the correct device.
- Eliminate the time-consuming process of locating and transcribing nameplates to view asset information.

---

#### Contents

Features and benefits.....	2
Ordering information.....	5
Specifications .....	17
Dimensional drawings.....	32
Product certifications.....	47

## Rosemount 644 selection guide

### Rosemount 644 HART® Transmitters

#### HART head mount and field mount

Figure 1: HART Head Mount



Figure 2: HART Field Mount



- Single or dual sensor inputs for:
  - RTD
  - thermocouple
  - mV
  - ohm
- DIN A head mount and field mount transmitters
- Safety integrity level (SIL) 3 capable: IEC 61508 certified by an accredited third-party agency for use in safety instrumented systems up to SIL 3 (minimum requirement of single use [1oo1] for SIL 2 and redundant use [1oo2] for SIL 3)
- LCD display
- Enhanced display with local operator interface (LOI)
- Integral transient protection
- Diagnostic suite
- Enhanced accuracy and stability
- Transmitter-sensor matching with Callendar-Van Dusen constants

## Rosemount 644 FOUNDATION™ Fieldbus



- Single sensor input for RTD, thermocouple, mV, and ohm
- DIN A head mount transmitter
- Standard function blocks: two analog inputs, one PID, and one backup Link Active Scheduler (LAS)
- LCD display
- ITK 5.01 compliant
- Transmitter–sensor matching with Callendar-Van Dusen constants
- Integral transient protection

## Rosemount 644 PROFIBUS® PA



- Single sensor input for RTD, thermocouple, mV, and ohm
- DIN A head mount transmitter
- Standard function blocks: one physical, one transducer, and one analog output
- LCD display
- Compliant to PROFIBUS PA Profile 3.02
- Transmitter–sensor matching with Callendar-Van Dusen constants

### Easy to use human-centered designs to make your job simple

- Diagnostic information and process health at your fingertips with intuitive device dashboards (DD).
- Communication clips are easily accessible when an LCD display is attached.

- Easy wiring practices with captive sensor screw terminals, an optimized wiring diagram, and field mount enclosure option.

### Optimize plant efficiency and increase visibility into the process with an expansive diagnostic offering

- Keep your process up and running with the Hot Backup™ feature where if your primary sensor fails, a second sensor seamlessly takes over and prevents the measurement failure.
- Tighten control with sensor drift alert that detects drifting sensors and proactively notifies the user.
- Enable predictive maintenance practices with thermocouple degradation diagnostic that monitors the health of the thermocouple loop.
- Improve quality with minimum and maximum temperature tracking that records temperature extremes of the process and the ambient environment.

## Ordering information



The versatile Rosemount 644 Temperature Transmitter meets demanding processing needs by delivering field reliability and advanced accuracy and stability.

Transmitter features include:

- HART®/4–20 mA with Selectable Revision 5 and 7 (option code A), FOUNDATION™ Fieldbus (option code F), or PROFIBUS® PA (option code W)
- Head mount - Dual sensor (option code S)
- Field mount - Dual sensor (option code D)
- Safety certified to IEC 61508 with Certificate of Failure Mode Evaluation Diagnostics and Analysis (FMEDA) Data (option code QT)
- LCD display (option code M5)
- Local operator interface (LOI) (option code M4)
- Advanced diagnostics (option codes DC and DA1)
- Enhanced transmitter accuracy and stability (option code P8)
- Transmitter-sensor matching (option code C2)

[CONFIGURE >](#)

[VIEW PRODUCT >](#)

## Online product configurator

Many products are configurable online using our product configurator.

Select the **Configure** button or visit [Emerson.com/global](https://www.emerson.com/global) to start. With this tool's built-in logic and continuous validation, you can configure your products more quickly and accurately.

## Model codes

Model codes contain the details related to each product. Exact model codes will vary. An example of a typical model code is shown in [Figure 3](#).

**Figure 3: Model code example**

**3144P D1 A 1 NA    M5 DA1 Q4**

**1                      2**

1. Required model components <sup>(1)</sup>
2. Additional options <sup>(2)</sup>

## Specifications and options

The purchaser of the equipment must specify and select:

- Product materials
- Options
- Components

## Optimizing lead time

The starred offerings (★) represent the most common options and should be selected for the fastest delivery. The non-starred offerings are subject to additional delivery lead time.

## Required model components

### Model

Code	Description	
644	Temperature transmitter	★

### Transmitter type

Code	Description	
H	DIN A head mount - single sensor input	★
S	DIN A head mount - dual sensor input (HART® only)	★
F <sup>(1)</sup>	Field mount - single sensor input (HART only)	★
D <sup>(1)</sup>	Field mount - dual sensor input (HART only)	★

(1) Consult factory on availability.

(1) Choices available on most.

(2) Variety of features and functions that may be added to products.

## Output

Code	Description	Head	Rail	
A	4–20 mA with digital signal based on HART® Protocol	•	•	★
F <sup>(1)</sup>	FOUNDATION™ Fieldbus digital signal (includes 2 analog input [AI] function blocks and backup Link Active Scheduler [LAS])	•	-	★
W <sup>(1)</sup>	PROFIBUS® PA digital signal	•	-	★

(1) Only available with H (single sensor).

## Product certifications

Hazardous locations certificates (consult factory for availability)

### Note

See [Table 1](#) for the validity of enclosures with individual approval options.

Code	Description	Head			Rail	
		A	F	W	A	
NA	No approval	•	•	•	•	★
E5	USA Explosion-proof; Dust Ignition-proof	•	•	•	-	★
I5	USA Intrinsically Safe; Non-incendive	•	•	•	•	★
K5	USA Explosion-proof; Intrinsically Safe; Non-incendive; Dust Ignition-proof	•	•	•	-	★
NK	IECEX Dust	•	•	-	-	★
KC	USA and Canada Intrinsically Safe and Non-incendive	-	-	-	•	★
KB	USA and Canada: Explosion-proof; Intrinsically Safe; Non-incendive; Dust Ignition-proof	•	-	-	-	★
KD	USA, Canada, and ATEX Explosion-proof, Intrinsically Safe	•	•	•	-	★
I6	Canada Intrinsically Safe	•	•	•	•	★
K6	Canada Explosion-proof; Intrinsically Safe; Non-incendive; Dust Ignition-proof	•	•	•	-	★
I3	China Intrinsic Safety	•	•	-	-	★
E3	China Flameproof	•	•	•	-	★
N3	China Type n	•	•	-	-	★
E1	ATEX Flameproof	•	•	•	-	★
N1	ATEX Type n	•	•	•	-	★
NC	ATEX Type n Component	•	•	•	•	★
K1	ATEX Flameproof; Intrinsic Safety; Type n; Dust	•	•	•	-	★
ND	ATEX Dust Ignition-Proof	•	•	•	-	★
KA	Canada and ATEX: Explosion-proof; Intrinsically Safe; Non-incendive	•	-	-	-	★
I1	ATEX Intrinsic Safety	•	•	•	•	★
E7	IECEX Flameproof	•	•	•	-	★
I7	IECEX Intrinsic Safety	•	•	•	•	★
N7	IECEX Type n	•	•	•	-	★
NG	IECEX Type n Component	•	•	•	•	★
K7	IECEX Flameproof; Intrinsic Safety; Type n; Dust	•	•	-	-	★
I2	INMETRO Intrinsic Safety	•	•	•	-	★

Code	Description	Head			Rail	
		A	F	W	A	
E4	Japan Flameproof	•	•	-	-	★
I4	Japan Intrinsic Safety	-	•	-	-	★
E2	INMETRO Flameproof	•	•	•	-	★
EM	Technical Regulations Customs Union (EAC) Flameproof	•	•	•	-	★
IM	Technical Regulations Customs Union (EAC) Intrinsic Safety	•	•	•	•	★
KM	Technical Regulations Customs Union (EAC) Flameproof, Intrinsic Safety, and Dust Ignition-proof	•	•	•	-	★
EP	Korea Flameproof and Dust Ignition-proof	•	•	•	-	★
IP	Korea Intrinsic Safety	•	•	•	-	★
KP	Korean Intrinsic Safety, Flameproof	•	•	•	-	★

## Additional options

### Plantweb™ standard diagnostic functionality

Code	Description	Head			Rail	
		A	F	W	A	
DC <sup>(1)</sup>	Diagnostics: Hot Backup™ and sensor drift alert	•	-	-	-	★
DA1	HART® sensor and process diagnostic suite: thermocouple diagnostic and minimum/maximum tracking	•	-	-	-	★

(1) Only available with S (dual sensor).

## Enclosure

Code	Housing style	Material	Entry size	Diameter	Head			Rail	
					A	F	W	A	
J5 <sup>(1)(2)</sup>	Universal junction box, 2 entries	Aluminum	M20 × 1.5	3 in. (76 mm)	•	•	•	-	★
J6 <sup>(2)</sup>	Universal junction box, 2 entries	Aluminum	½-14 NPT	3 in. (76 mm)	•	•	•	-	★
R1	Rosemount connection head, 2 entries	Aluminum	M20 × 1.5	3 in. (76 mm)	•	•	•	-	★
R2	Rosemount connection head, 2 entries	Aluminum	½-14 NPT	3 in. (76 mm)	•	•	•	-	★
J1 <sup>(1)</sup>	Universal junction box, 3 entries	Aluminum	M20 × 1.5	3.5 in. (89 mm)	•	•	•	-	★
J2	Universal junction box, 3 entries	Aluminum	½-14 NPT	3.5 in. (89 mm)	•	•	•	-	★
D1 <sup>(1)(3)</sup>	Field mount housing, separate terminal compartment	Aluminum	M20 × 1.5	3.5 in. (89 mm)	-	-	-	-	★

Code	Housing style	Material	Entry size	Diameter	Head			Rail	
					A	F	W	A	
D2 <sup>(3)</sup>	Field mount housing, separate terminal compartment	Aluminum	½-14 NPT	3.5 in. (89 mm)	-	-	-	-	★
J3 <sup>(1)</sup>	Universal junction box, 3 entries	Cast SST	M20 × 1.5	3.5 in. (89 mm)	•	•	•	-	
J4	Universal junction box, 3 entries	Cast SST	½-14 NPT	3.5 in. (89 mm)	•	•	•	-	
J7 <sup>(1)(2)</sup>	Universal junction box, 2 entries	Cast SST	M20 × 1.5	3 in. (76 mm)	•	•	•	-	
J8 <sup>(2)</sup>	Universal junction box, 2 entries	Cast SST	½-14 NPT	3 in. (76 mm)	•	•	•	-	
R3	Rosemount connection head, 2 entries	Cast SST	M20 × 1.5	3 in. (76 mm)	•	•	•	-	
R4	Rosemount connection head, 2 entries	Cast SST	½-14 NPT	3 in. (76 mm)	•	•	•	-	
S1	Connection head, 2 entries	Polished SST	½-14 NPT	3 in. (76 mm)	•	•	•	-	
S2	Connection head, 2 entries	Polished SST	½-14 NPSM	3 in. (76 mm)	•	•	•	-	
S3	Connection head, 2 entries	Polished SST	M20 × 1.5	3 in. (76 mm)	•	•	•	-	
S4	Connection head, 2 entries	Polished SST	M20 × 1.5, M24 × 1.4	3 in. (76 mm)	•	•	•	-	

(1) When ordered with XA, ½-in. NPT enclosure will come equipped with an M20 adapter with the sensor installed as a process ready.

(2) Enclosure ships equipped with 2-in. (51 mm) stainless steel (SST) pipe U-bolt mounting kit except when ordered with XA.

(3) Only available with transmitter types 644F and 644D.

## Mounting bracket

Bracket assembly is only available with [Enclosure](#).

Code	Description	Head			Rail	
		A	F	W	A	
B4	316 stainless steel (SST) U-bolt mounting bracket, 2-in. pipe mount	•	•	•	•	★
B5	"L" mounting bracket for 2-in. pipe or panel mounting	•	•	•	•	★

## Display and interface

Code	Description	Head			Rail	
		A	F	W	A	
M4	LCD display with local operator interface (LOI)	•	-	-	-	★
M5	LCD display	•	•	•	-	★

### Software configuration

Code	Description	Head			Rail	
		A	F	W	A	
C1	Custom configuration of date, descriptor, and message (requires Configuration Data Sheet [CDS] with order)	•	•	•	•	★

### Enhanced performance

See [Table 18](#) for enhanced accuracy specifications.

Code	Description	Head			Rail	
		A	F	W	A	
P8	Enhanced transmitter accuracy and stability	•	-	-	-	★

### Alert level configuration

Code	Description	Head			Rail	
		A	F	W	A	
A1	NAMUR alarm and saturation levels, high alarm	•	-	-	•	★
CN	NAMUR alarm and saturation levels, low alarm	•	-	-	•	★
C8	Low alarm (standard Rosemount alarm and saturation values)	•	-	-	•	★

### Line filter

Code	Description	Head			Rail	
		A	F	W	A	
F5	50 Hz line voltage filter	•	•	•	•	★
F6	60 Hz line voltage filter	•	•	•	•	★

### Sensor trim

Code	Description	Head			Rail	
		A	F	W	A	
C2	Transmitter sensor matching - trim to specific Rosemount RTD calibration schedule (CVD constants)	•	•	•	•	★

### 5-Point calibration

Code	Description	Head			Rail	
		A	F	W	A	
C4	5-Point calibration (use option code Q4 to generate a calibration certificate)	•	•	•	•	★

## Calibration certificate

Code	Description	Head			Rail	
		A	F	W	A	
Q4	Calibration certificate (3-Point calibration with certificate)	•	•	•	•	★
QP	Calibration certification and tamper evident seal	•	-	-	-	★

## Custody transfer

Code	Description	Head			Rail	
		A	F	W	A	
D4	MID Custody Transfer (Europe)	•	-	-	-	★

## Quality certification for safety

Code	Description	Head			Rail	
		A	F	W	A	
QT	Safety Certified to IEC 61508 with certificate of Failure Mode Evaluation Diagnostics and Analysis (FMEDA) data	•	-	-	-	★

## Shipboard certification

Code	Description	Head			Rail	
		A	F	W	A	
SBS	American Bureau of Shipping (ABS) Type Approval	•	•	•	-	★
SBV	Bureau Veritas (BV) Type Approval	•	•	•	-	★
SDN	Det Norske Veritas (DNV) Type Approval	•	•	•	-	★
SLL	Lloyd's Register (LR) Type Approval	•	•	•	-	★

## External ground

Code	Description	Head			Rail	
		A	F	W	A	
G1	External ground lug assembly (see <a href="#">External ground screw assembly</a> )	•	•	•	-	★

## Transient protection

Transient protection option requires the use of [Enclosure](#).

Transient protection with output option code F only available with [Product certifications](#).

Code	Description	Head			Rail	
		A	F	W	A	
T1	Integral transient protector	•	•	-	-	★

## Cable gland

Code	Description	Head			Rail	
		A	F	W	A	
G2	Cable gland (7.5–11.99 mm)	•	•	•	–	★
G7	Cable gland, M20 × 1.5, Ex e, blue polyamide (5–9 mm)	•	•	•	–	★

## Cover chain

Code	Description	Head			Rail	
		A	F	W	A	
G3	Cover chain	•	•	•	–	★

## Conduit electric connector

This option is available with [Product certifications](#) only. For USA Intrinsically Safe or non-incendive approval ([Product certifications](#)), install in accordance with Rosemount drawing 03151-1009.

Code	Description	Head			Rail	
		A	F	W	A	
GE	M12, 4-pin, male connector (eurofast®)	•	•	•	–	★
GM	A size mini, 4-pin, male connector (minifast®)	•	•	•	–	★

## External label

Code	Description	Head			Rail	
		A	F	W	A	
EL	External label for ATEX Intrinsic Safety	•	•	•	–	★

## HART® revision configuration

Code	Description	Head			Rail	
		A	F	W	A	
HR5	Configured for HART Revision 5	•	–	–	–	★
HR7 <sup>(1)</sup>	Configured for HART Revision 7	•	–	–	–	★

<sup>(1)</sup> Configures the HART output to HART Revision 7. If needed, the device can be field configured to HART Revision 5.

## Assemble to options

Code	Description	Head			Rail	
		A	F	W	A	
XA	Sensor specified separately and assembled to transmitter	•	•	•	–	★

## Extended product warranty

Code	Description	Head			Rail	
		A	F	W	A	
WR3	3-year limited warranty	•	•	•	•	★
WR5	5-year limited warranty	•	•	•	•	★

## Enclosure option valid with individual approval codes

### Note

For additional options, such as K codes, contact your local Emerson representative.

**Table 1: Rosemount 644 enclosure options valid with individual approval codes**

Code	Hazardous location approval description	Enclosure option valid with approval
NA	No approval	J1, J2, J3, J4, R1, R2, R3, R4, J5, J6, J7, J8, S1, S2, S3, S4, D1, D2
E5	USA Explosion-proof; Dust Ignition-proof	J1, J2, J3, J4, R1, R2, R3, R4, J5, J6, J7, J8, D1, D2
I5	USA Intrinsically Safe; Non-incendive	J1, J2, J3, J4, R1, R2, R3, R4, J5, J6, J7, J8, D1, D2
K5	USA Explosion-proof; Intrinsically Safe; Non-incendive; Dust Ignition-proof	J1, J2, J3, J4, R1, R2, R3, R4, J5, J6, J7, J8, D1, D2
NK	IECEX Dust	J1, J2, J3, J4, R1, R2, R3, R4, J5, J6, J7, J8, D1, D2
KC	USA and Canada Intrinsically Safe and Non-incendive	Only available with rail mount device
KB	USA and Canada: Explosion-proof; Intrinsically Safe; Non-incendive; Dust Ignition-proof	J2, J4, R2, R4, J6, J8, D2
KD	USA, Canada, and ATEX Explosion-proof, Intrinsically Safe	J2, J4, R2, R4, J6, J8, D2
I6	Canada Intrinsically Safe	J1, J2, J3, J4, R1, R2, R3, R4, J5, J6, J7, J8, D1, D2
K6	Canada Explosion-proof; Intrinsically Safe; Non-incendive; Dust Ignition-proof	J2, J4, R2, R4, J6, J8, D2
I3	China Intrinsic Safety	J1, J2, J3, J4, R1, R2, R3, R4, J5, J6, J7, J8, D1, D2
E3	China Flameproof	R1, R2, R3, R4, J1, J2, J3, J4, J5, J6, J7, J8, D1, D2
N3	China Type n	R1, R2, R3, R4, J1, J2, J3, J4, J5, J6, J7, J8, D1, D2
E1	ATEX Flameproof	J1, J2, J3, J4, R1, R2, R3, R4, J5, J6, J7, J8, D1, D2
N1	ATEX Type n	J1, J2, J3, J4, R1, R2, R3, R4, J5, J6, J7, J8, D1, D2
NC	ATEX Type n Component	None
K1	ATEX Flameproof; Intrinsic Safety; Type n; Dust	J1, J2, J3, J4, R1, R2, R3, R4, J5, J6, J7, J8, D1, D2
ND	ATEX Dust Ignition-Proof	J1, J2, J3, J4, R1, R2, R3, R4, J5, J6, J7, J8, D1, D2
KA	Canada and ATEX: Explosion-proof; Intrinsically Safe; Non-incendive	J2, J4, R2, R4, J6, J8, D2
I1	ATEX Intrinsic Safety	J1, J2, J3, J4, R1, R2, R3, R4, J5, J6, J7, J8, S1, S2, S3, S4, D1, D2
E7	IECEX Flameproof	J1, J2, J3, J4, R1, R2, R3, R4, J5, J6, J7, J8, D1, D2
I7	IECEX Intrinsic Safety	J1, J2, J3, J4, R1, R2, R3, R4, J5, J6, J7, J8, S1, S2, S3, S4, D1, D2
N7	IECEX Type n	J1, J2, J3, J4, R1, R2, R3, R4, J5, J6, J7, J8, D1, D2
NG	IECEX Type n Component	None

**Table 1: Rosemount 644 enclosure options valid with individual approval codes (continued)**

Code	Hazardous location approval description	Enclosure option valid with approval
K7	IECEX Flameproof; Intrinsic Safety; Type n; Dust	J1, J2, J3, J4, R1, R2, R3, R4, J5, J6, J7, J8, D1, D2
I2	INMETRO Intrinsic Safety	J1, J2, J3, J4, R1, R2, R3, R4, J5, J6, J7, J8
E4	Japan Flameproof	J2, J6
E2	INMETRO Flameproof	R1, R2, R3, R4, J1, J2, J3, J4, J5, J6, J7, J8, D1, D2
KM	Technical Regulations Customs Union (EAC) Flameproof, Intrinsic Safety, and Dust Ignition-proof	J1, J2, J3, J4, J5, J6, J7, J8, R1, R2, R3, R4,
IM	Technical Regulations Customs Union (EAC) Intrinsic Safety	J1, J2, J3, J4, J5, J6, J7, J8, R1, R2, R3, R4, S1, S2, S3, S4
EM	Technical Regulations Customs Union (EAC) Flameproof	J1, J2, J3, J4, J5, J6, J7, J8, R1, R2, R3, R4,
K2	INMETRO Flameproof, Intrinsic Safety	R1, R2, R3, R4, J1, J2, J3, J4, J5, J6, J7, J8
IP	Korea Intrinsic Safety	D1, D2, J1, J2, J3, J4, J5, J6, J7, J8, R1, R2, R3, R4
EP	Korea Flameproof and Dust Ignition-proof	D1, D2, J1, J2, J3, J4, J5, J6, J7, J8, R1, R2, R3, R4
KP	Korean Intrinsic Safety, Flameproof	D1, D2, J1, J2, J3, J4, J5, J6, J7, J8, R1, R2, R3, R4

## Tagging

### Hardware

- 18 characters total
- Tags are adhesive or metal labels
- Tag is permanently attached to transmitter

### Software

The transmitter can store up to 32 characters for FOUNDATION™ Fieldbus and PROFIBUS® PA or 8 for HART® protocol. If no characters are specified, the first 8 characters of the hardware tag are the default. An optional 32-character software tag is available when option code HR7 is ordered.

### Considerations

#### External ground screw assembly

The external ground screw assembly can be ordered by specifying [Table 2](#) when an enclosure is specified. However, some approvals include the ground screw assembly in the transmitter shipment, so it is not necessary to order code G1. [Table 2](#) identifies which approval options include the external ground screw assembly and which do not.

**Table 2: External ground screw assembly**

Option code	External ground screw assembly included?
E5, I1, I2, I3, I4, I5, I6, I7, IM, IP, K5, K6, NA, KB	No-order option code G1
E1, E2, E3, E4, E7, EM, EP, KM, KP, K7, N1, N7, ND, K1, K2, KA, NK, N3, KD, T1	Yes

**Table 3: Enclosure spares**

Description	Part number
Universal head, aluminum, standard cover, 2-conduit - M20 entries	00644-4420-0002
Universal head, aluminum, display cover, 2-conduit - M20 entries	00644-4420-0102

**Table 3: Enclosure spares (continued)**

Description	Part number
Universal head, aluminum, standard cover, 2-conduit - ½-14 NPT entries	00644-4420-0001
Universal head, aluminum, display cover, 2-conduit - ½-14 NPT entries	00644-4420-0101
Universal head, stainless steel (SST), standard cover, 2-conduit - M20 entries	00644-4433-0002
Universal head, SST, display cover, 2-conduit - M20 entries	00644-4433-0102
Universal head, SST, standard cover, 2-conduit - ½-14 NPT entries	00644-4433-0001
Universal head, SST, display cover, 2-conduit - ½-14 NPT entries	00644-4433-0101
Connection head, aluminum, standard cover, 2-conduit - M20 × ½ ANPT entries	00644-4410-0021
Connection head, aluminum, display cover, 2-conduit - M20 × ½ ANPT entries	00644-4410-0121
Connection head, aluminum, standard cover, 2-conduit - ½-14 NPT × ½ ANPT entries	00644-4410-0011
Connection head, aluminum, display cover, 2-conduit - ½-14 NPT × ½ ANPT entries	00644-4410-0111
Connection head, SST, standard cover, 2-conduit - M20 × ½ ANPT entries	00644-4411-0021
Connection head, SST, display cover, 2-conduit - M20 × ½ ANPT entries	00644-4411-0121
Connection head, SST, standard cover, 2-conduit - ½-14 NPT × ½ ANPT entries	00644-4411-0011
Connection head, SST, display cover, 2-conduit - ½-14 NPT × ½ ANPT entries	00644-4411-0111
Connection head, polished SST, standard cover, 2-conduit - M20 × 1.5 entries	00079-0312-0033
Connection head, polished SST, display cover, 2-conduit - M20 × 1.5 entries	00079-0312-0133
Connection head, polished SST, standard cover, 2-conduit - M20 × 1.5/M24 × 1.5 entries	00079-0312-0034
Connection head, polished SST, display cover, 2-conduit - M20 × 1.5/M24 × 1.5 entries	00079-0312-0134
Connection head, polished SST, standard cover, 2-conduit - ½ -14 NPT entries	00079-0312-0011
Connection head, polished SST, display cover, 2-conduit - ½-14 NPT entries	00079-0312-0111
Connection head, polished SST, standard cover, 2-conduit - ½-14 NPSM entries	00079-0312-0022
Connection head, polished SST, display cover, 2-conduit - ½-14 NPSM entries	00079-0312-0122
Universal head, aluminum, standard cover, 3-conduit - M20 entries	00644-4439-0001
Universal head, aluminum, display cover, 3-conduit - M20 entries	00644-4439-0101
Universal head, aluminum, standard cover, 3-conduit - ½-14 NPT entries	00644-4439-0002
Universal head, aluminum, display cover, 3-conduit - ½-14 NPT entries	00644-4439-0102
Universal head, SST, standard cover, 3-conduit - M20 entries	00644-4439-0003
Universal head, SST, display cover, 3-conduit - M20 entries	00644-4439-0103
Universal head, SST, standard cover, 3-conduit - ½ - 14 NPT entries	00644-4439-0004
Universal head, SST, display cover, 3-conduit - ½ - 14 NPT entries	00644-4439-0104

**Table 4: Display kit spares**

Description	Part number
<b>Display only</b>	
Rosemount 644 HART LCD display (option M5)	00644-7730-0001
Rosemount 644 HART local operator interface (LOI) (option M4)	00644-7730-1001
Rosemount 644 FOUNDATION Fieldbus LCD display (option M5)	00644-4430-0002
Rosemount 644 PROFIBUS PA LCD display (option M5)	00644-4430-0002

**Table 4: Display kit spares (continued)**

Description	Part number
Rosemount 644 HART Legacy display kit (option M5 - device rev 7)	00644-4430-0002
<b>Display with aluminum cover</b>	
Rosemount 644 HART LCD display (option M5)	00644-7730-0011
Rosemount 644 HART LCD display (option M5 - for use with options J1-J2)	00644-7730-0111
Rosemount 644 HART LOI (option M4)	00644-7730-1011
Rosemount 644 HART LOI (option M4 - for use with options J1-J2)	00644-7730-1111
Rosemount 644 FOUNDATION Fieldbus LCD display (option M5)	00644-4430-0001
Rosemount 644 PROFIBUS PA LCD display (option M5)	00644-4430-0001
Rosemount 644 HART Legacy display kit (option M5)	00644-4430-0001
<b>Display with SST meter cover</b>	
Rosemount 644 HART LCD display (option M5) <sup>(1)</sup>	00644-7730-0021
Rosemount 644 HART LCD display (option M5) <sup>(2)</sup>	00644-7730-0121
Rosemount 644 HART LOI (option M4) <sup>(1)</sup>	00644-7730-1021
Rosemount 644 HART LOI (option M4) <sup>(2)</sup>	00644-7730-1121
Rosemount 644 FOUNDATION Fieldbus LCD display (option M5) <sup>(1)</sup>	00644-4430-0011
Rosemount 644 PROFIBUS PA LCD display (option M5) <sup>(1)</sup>	00644-4430-0011
Rosemount 644 HART Legacy display kit (option M5) <sup>(1)</sup>	00644-4430-0011

(1) Covers provided are compatible with the 3-in. (76 mm) universal junction box and Rosemount connection head enclosure styles.

(2) Cover provided is compatible with the 3.5-in. (89 mm) universal junction box and field mount enclosure styles.

**Table 5: Transient protection spares**

Description	Part number
HART transient protector without enclosure	00644-4537-0001
HART transient protector with universal head, aluminum, standard cover, 3-conduit - M20	00644-4538-0001
HART transient protector with universal head, aluminum, display cover, 3-conduit - M20	00644-4538-0101
HART transient protector with universal head, aluminum, standard cover, 3-conduit - ½ NPT	00644-4538-0002
HART transient protector with universal head, aluminum, display cover, 3-conduit - ½ NPT	00644-4538-0102
HART transient protector with universal head, SST, standard cover, 3-conduit - M20	00644-4538-0003
HART transient protector with universal head, SST, display cover, 3-conduit - M20	00644-4538-0103
HART transient protector with universal head, SST, standard cover, 3-conduit - ½-NPT	00644-4538-0004
HART transient protector with universal head, SST, display cover, 3-conduit - ½-NPT	00644-4538-0104
FOUNDATION Fieldbus transient protector without enclosure	00644-4539-0001

**Table 6: Miscellaneous accessories**

Description	Part number
Stainless steel meter housing cover, Fieldbus extended	03031-0199-0025
Ground screw assembly kit <sup>(1)</sup>	00644-4431-0001
Mounting screws and springs	00644-4424-0001
Hardware kit for mounting a Rosemount 644 head mount to a DIN rail (includes clips for symmetrical and asymmetrical rails)	00644-5301-0010

**Table 6: Miscellaneous accessories (continued)**

Description	Part number
Hardware kit for retrofitting a Rosemount 644 head mount in an existing threaded sensor connection head (former option code L1)	00644-5321-0010
U-bolt mounting kit for universal housing	00644-4423-0001
U-bolt mounting bracket, 2-in. pipe mount - 316 SST (option B4)	00644-7610-0001
L-mounting bracket for 2-in. pipe or panel mounting, SST, 2 g vibration rating (option B5)	00644-7611-0001
Universal clip for rail or wall mount	03044-4103-0001
24-in. of symmetric (top hat) rail	03044-4200-0001
24-in. of asymmetric (G) rail	03044-4201-0001
Ground clamp for symmetric or asymmetric rail	03044-4202-0001
Snap rings kit (used for assembly to a DIN sensor)	00644-4432-0001
Cover clamp assembly for 2-conduit J-box	00644-4434-0001
Cover clamp assembly for 3-conduit J-box	00644-4434-0002
Terminal block, 13 mm M4 mounting screws	00065-0305-0001

(1) *Compatible with the 3-in. (76 mm) universal junction box and Rosemount connection head enclosure styles.*

**Table 7: Housing covers**

Description	Part number
Standard cover- aluminum (J5, J6, R1, R2)	03031-0292-0001
Standard cover- SST (J7, J8, R3, R4)	03031-0292-0002
Aluminum meter cover (J5, J6, R1, R2)	03031-0199-0015
SST meter cover (J7, J8, R3, R4)	03031-0199-0025

## Specifications

### HART<sup>®</sup>, FOUNDATION<sup>™</sup> Fieldbus, and PROFIBUS<sup>®</sup> PA protocols

#### Functional specifications

##### Inputs

User-selectable; sensor terminals rated to 42.4 Vdc. See [Accuracy example \(FOUNDATION<sup>™</sup> Fieldbus and PROFIBUS<sup>®</sup> PA devices\)](#).

##### Output

Single two-wire device with either 4–20 mA/HART<sup>®</sup>, linear with temperature or input; or completely digital outputs with FOUNDATION<sup>™</sup> Fieldbus communication (ITK 5.01 compliant), or PROFIBUS<sup>®</sup> PA (compliant with profile 3.02).

##### Isolation

Input/output isolation tested to 620 Vrms.

##### Local display options

**LCD display** An optional, two-line integral LCD display operates with a floating or fixed decimal point. It displays engineering units (°F, °C, °R, K, ohms and mV), mA, and percent of range. The display can be

configured to alternate between selected display options. Display settings are pre-configured at the factory according to the standard transmitter configuration. They can be re-configured in the field using either HART, FOUNDATION Fieldbus, or PROFIBUS PA communications.

**LCD display with local operator interface (LOI)**

An optional, two-line, integral LCD display operates with a floating or fixed decimal point. The LOI includes all features and functionality available in the regular display with an added two-button configuration capability directly at the display interface. The LOI also has optional password protection for secure operations. The LOI is only available on the Rosemount 644 HART head mount and field mount transmitters.

For more information on the LOI configuration options or further functionality that the LOI offers, see the [Rosemount 644 Temperature Transmitter Reference Manual](#).

**Humidity limits**

0–95 percent relative humidity

**Update time**

≤0.5 second per sensor

**Accuracy (default configuration) PT 100**

HART standard: ±0.1°C

HART enhanced: ±0.08 °C

FOUNDATION Fieldbus: ±0.15 °C

PROFIBUS PA: ±0.15 °C

**Physical specifications**

**Material selection**

Emerson provides a variety of Rosemount products with various product options and configurations, including materials of construction that can be expected to perform well in a wide range of applications. The Rosemount product information presented is intended as a guide for the purchaser to make an appropriate selection for the application. It is the purchaser's sole responsibility to make a careful analysis of all process parameters (such as all chemical components, temperature, pressure, flow rate, abrasives, contaminants, etc.), when specifying product, materials, options, and components for the particular application. Emerson is not in a position to evaluate or guarantee the compatibility of the process fluid or other process parameters with the product, options, configuration, or materials of construction selected.

**Conformance to specifications (±3σ [Sigma])**

Technology leadership, advanced manufacturing techniques, and statistical process control ensure specification conformance to at least ±3σ.

**Table 8: Electrical connections**

Rosemount model	Power and sensor terminals
Head mount (HART®)	Captivated screw terminals permanently fixed to terminal block
Head mount (FOUNDATION™ Fieldbus/PROFIBUS® PA)	Compression screw terminals permanently fixed to the terminal block
Field mount (HART)	Captivated screw terminals permanently fixed to the terminal block

**Table 9: Field Communicator connections**

Communication terminals	
Rosemount 644 head/field mount	Clips permanently fixed to terminal block

**Table 10: Materials of construction**

Electronics housing and terminal block	
Rosemount 644 head/ field mount	GE polyphenylene oxide glass reinforced GFN -2 or -3
Enclosure (Options J1, J2, J5, J6, R1, R2, D1, and D2)	
Housing	Low-copper aluminum
Paint	Polyurethane
Cover O-ring	Buna-N

### Materials of construction (stainless steel housing for biotechnology, pharmaceutical industries, and sanitary applications)

Housing and standard meter cover

- 316 stainless steel (SST)

Cover O-ring

- Buna-N

### Mounting

The Rosemount 644R attaches directly to a wall or a DIN rail. The Rosemount 644H installs in a connection head or universal head mounted directly on a sensor assembly, apart from a sensor assembly using a universal head, or to a DIN rail using an optional mounting clip.

### Special mounting considerations

See mounting kits for Rosemount 644H for the special hardware that is available to:

- Mount a Rosemount 644H to a DIN rail (see [Dimensional drawings](#)).
- Retrofit a new Rosemount 644H to replace an existing Rosemount 644H Transmitter in an existing threaded sensor connection head (see [Table 3](#)).

**Table 11: Weight**

Code	Options	Weight
644H	HART, head mount transmitter	2.75 oz. (78 g)
644H	FOUNDATION Fieldbus, head mount transmitter	3.25 oz. (92 g)
644H	PROFIBUS PA, head mount transmitter	3.25 oz. (92 g)
M5	LCD display	1.2 oz. (34 g)
M4	LCD display with local operator interface	1.2 oz. (34 g)
J1, J2	Universal head, 3-conduits, standard cover	25.33 oz. (718 g)
J1, J2	Universal head, 3-conduits, meter cover	29.14 oz. (826 g)
J3, J4	Cast SST universal head, 3-conduits, standard cover	73.12 oz. (2073 g)
J3, J4	Cast SST universal head, 3-conduits, meter cover	75.77 oz. (2148 g)
J5, J6	Aluminum 2-conduits, universal head, standard cover	18.43 oz. (520 g)
J5, J6	Aluminum 2-conduits, universal head, meter cover	21.27 oz. (604 g)
J7, J8	Cast SST universal head, 2-conduits, standard, cover	59.0 oz. (1673 g)
J7, J8	Cast SST universal head, 2-conduits, meter cover	64.73 oz. (1835 g)
R1, R2	Aluminum connection head, standard cover	18.45 oz. (523 g)
R1, R2	Aluminum connection head, meter cover	21.89 oz. (618 g)
R3, R4	Cast SST connection head, standard cover	56.97 oz. (1615 g)

**Table 11: Weight (continued)**

Code	Options	Weight
R3, R4	Cast SST connection head, meter cover	61.62 oz. (1747 g)
D1, D2	HART, field mount transmitter, aluminum housing, meter cover, standard cover	39.79 oz. (1128 g)

**Table 12: Weight (stainless steel housing for biotechnology, pharmaceutical industries, and sanitary applications)**

Option codes	Standard cover	Meter cover
S1, S2, S3, S4	27 oz. (840 g)	32 oz. (995 g)

**Enclosure ratings (Rosemount 644H/F)**

All available enclosures are Type 4X, IP66, and IP68.

**Sanitary housing surface**

Surface finish is polished to 32 RMA. Laser etched product marking on housing and standard covers.

**Performance specifications****Electromagnetic compatibility (EMC)**

Meets all industrial environment requirements of EN61326 and NAMUR NE-21. Maximum deviation <1% span during EMC disturbance.

**Note**

During surge event, device may exceed maximum EMC deviation limit or reset; however, device will self-recover and return to normal operation within specified start-up time.

**Power supply effect**

Less than  $\pm 0.005$  percent of span per volt

**Stability**

RTDs and thermocouples have a stability of  $\pm 0.15$  percent of output reading or  $0.15\text{ }^{\circ}\text{C}$  (whichever is greater) for 24 months.

When ordered with the P8 option code:

- RTDs:  $\pm 0.25$  percent of reading or  $0.25\text{ }^{\circ}\text{C}$ , whichever is greater, for five years
- Thermocouples:  $\pm 0.5$  percent of reading or  $0.5\text{ }^{\circ}\text{C}$ , whichever is greater, for five years

**Self calibration**

The analog-to-digital measurement circuitry automatically self-calibrates for each temperature update by comparing the dynamic measurement to extremely stable and accurate internal reference elements.

**Table 13: Vibration effect**

The Rosemount 644 HART<sup>®</sup> head mount and field mount are tested to the following specifications with no effect on performance per IEC 60770-1, 2010:

Frequency	Vibration
10–60 Hz	0.013-in. (0.35 mm) displacement
60–1000 Hz	5g (164 ft./s <sup>2</sup> [50 m/s <sup>2</sup> ]) peak acceleration

The Rosemount 644 FOUNDATION™ Fieldbus and PROFIBUS® are tested to the following specifications with no effect on performance per IEC 60770-1: 1999:

Frequency	Vibration
10-60 Hz	0.008-in. (0.21 mm) displacement
60-2000 Hz	3 g peak acceleration

**Table 14: Rosemount 644 Sensor connection diagrams**

Emerson provides 4-wire sensors for all single element RTDs. You can use these RTDs in 3-wire configurations by leaving the unneeded leads disconnected and insulated with electrical tape.

**HART head mount**





Single Input Wiring	2-wire RTD and $\Omega$ 	3-wire RTD and $\Omega$ 
	4-wire RTD and $\Omega$ 	T/C and mV 
Dual Input Wiring	Dual 2-wire RTD and $\Omega$ 	Dual 3-wire RTD and $\Omega$ 
	Dual T/C and mV 	

Table 14: Rosemount 644 Sensor connection diagrams (continued)

<p><b>HART field mount</b></p> 	<table border="1"> <tr> <td data-bbox="821 315 964 378">A</td> <td data-bbox="977 315 1211 436">B</td> <td data-bbox="1230 315 1464 436">C</td> </tr> <tr> <td></td> <td data-bbox="977 457 1211 579">D</td> <td data-bbox="1230 457 1464 579">E</td> </tr> <tr> <td data-bbox="821 609 964 672">F</td> <td data-bbox="977 609 1211 730">G</td> <td data-bbox="1230 609 1464 730">H</td> </tr> <tr> <td></td> <td data-bbox="977 751 1211 873">I</td> <td></td> </tr> </table> <p>A. Single input wiring          B. 2-wire RTD and <math>\Omega</math>          C. 3-wire RTD and <math>\Omega</math>          D. 4-wire RTD and <math>\Omega</math>          E. Thermocouple and mV          F. Dual input wiring          G. Dual 2-wire RTD and <math>\Omega</math>          H. Dual 3-wire RTD and <math>\Omega</math>          I. Dual thermocouple and mV</p>	A	B	C		D	E	F	G	H		I	
A	B	C											
	D	E											
F	G	H											
	I												

## FOUNDATION Fieldbus specifications

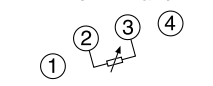
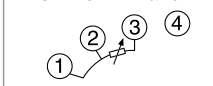
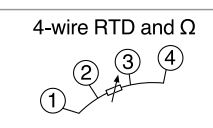
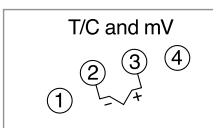
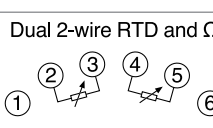
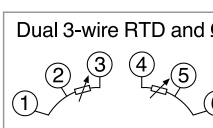
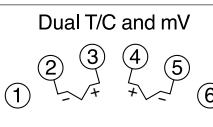
### Function blocks

#### Resource block

The resource block contains physical transmitter information including available memory, manufacture identification, device type, software tag, and unique identification.

#### Transducer block

The transducer block contains the actual temperature measurement data, including Sensor 1 and terminal temperature. It includes information about sensor type and configuration, engineering units, linearization, reranging, damping, temperature correction, and diagnostics.

#### LCD display block

If an LCD display is being used, the LCD display block is used to configure the local display.

#### Analog input (AI)

- Processes the measurement and makes it available on the Fieldbus segment.
- Allows filtering, alarming, and engineering unit changes.

### PID block

The transmitter provides control functionality with one PID function block in the transmitter. The PID block can be used to perform single loop, cascade, or feedforward control in the field.

Block	Execution time (milliseconds)
Resource	N/A
Transducer	N/A
LCD display block	N/A
Analog input 1	45
Analog Input 2	45
PID 1	60

### Turn-on time

Performance within specifications in less than 20 seconds after power is applied, when damping value is set to zero seconds.

### Status

If self-diagnostics detect a sensor burnout or a transmitter failure, the status of the measurement will be updated accordingly. Status may also send the AI output to a safe value.

### Power supply

Powered over FOUNDATION Fieldbus with standard Fieldbus power supplies. The transmitter operates between 9.0 and 32.0 Vdc, 12 mA maximum.

### Alarms

The AI function block allows the user to configure the alarms to HI-HI, HI, LO, or LO-LO with hysteresis settings.

### Backup Link Active Scheduler (LAS)

The transmitter is classified as a device link master, which means it can function as a LAS if the current link master device fails or is removed from the segment.

The host or other configuration tool is used to download the schedule for the application to the link master device. In the absence of a primary link master, the transmitter will claim the LAS and provide permanent control for the H1 segment.

### FOUNDATION Fieldbus parameters

Schedule entries	25
Links	16
Virtual Communications Relationships (VCR)	12

## PROFIBUS® PA specifications

### Function blocks

#### Physical block

The physical block contains physical transmitter information including manufacturer identification, device type, software tag, and unique identification.

**Transducer block**

The transducer block contains the actual temperature measurement data, including sensor 1 and terminal temperature. It includes information about sensor type and configuration, engineering units, linearization, re-ranging, damping, temperature correction, and diagnostics.

**Analog Input block (AI)**

The AI block processes the measurement and makes it available on the PROFIBUS segment. Allows filtering, alarming, and engineering unit changes.

**Turn-on time**

Performance within specifications in less than 20 seconds after power is applied, when damping value is set to zero seconds.

**Powersupply**

Powered over PROFIBUS® with standard Fieldbus™ power supplies. The transmitter operates between 9.0 and 32.0 Vdc, 12 mA maximum.

**Alarms**

The AI function block allows the user to configure the alarms to HI-HI, HI, LO, or LO-LO with hysteresis settings.

**4–20 mA/HART® specifications**

**Power supply**

External power supply required. Transmitters operate on 12.0–42.4 Vdc transmitter terminal voltage (with 250 ohm load, 18.1 Vdc power supply voltage is required). Transmitter power terminals rated to 42.4 Vdc.

**Figure 4: Load Limitations**

Maximum load =  $40.8 \times (\text{supply voltage} - 12.0)^{(1)}$

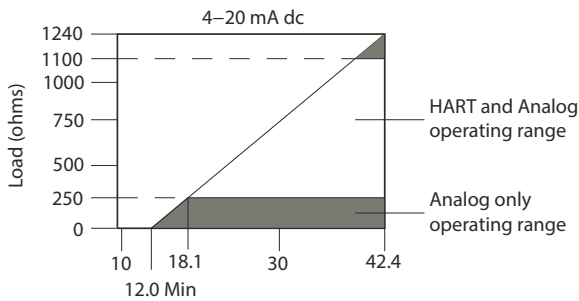

(1) Without transient protection (optional).

**Note**

HART® Communication requires a loop resistance between 250 and 1100 ohms. Do not communicate with the transmitter when power is below 12 Vdc at the transmitter terminals.

### Temperature limits

Description	Operating limit <sup>(1)</sup>	Storage limit <sup>(1)</sup>
With LCD display <sup>(2)</sup>	-40 to 185 °F -40 to 85 °C	-50 to 185 °F -45 to 85 °C
Without LCD display	-40 to 185 °F -40 to 85 °C	-58 to 250 °F -50 to 120 °C

(1) The lower operating and storage temperature limit of a transmitter with option code BR6 is -76 °F (-60 °C).

(2) LCD display may not be readable and display updates will be slower at temperatures below -22 °F (-30 °C).

### Hardware and software failure mode

The Rosemount 644 features software driven alarm diagnostics and an independent circuit, which is designed to provide backup alarm output if the microprocessor software fails. The alarm direction (HI/LO) is user-selectable using the failure mode switch. If failure occurs, the position of the switch determines the direction in which the output is driven (HI or LO). The switch feeds into the digital-to-analog (D/A) converter, which drives the proper alarm output even if the microprocessor fails. The values at which the transmitter software drives its output in failure mode depends on whether it is configured to standard, custom, or NAMUR-compliant (NAMUR recommendation NE 43, June 1997) operation. [Table 15](#) shows the configuration alarm ranges.

**Table 15: Available Alarm Range**

Units - mA	Min	Max	Rosemount	Namur
High alarm	21	23	21.75	21
Low alarm <sup>(1)</sup>	3.5	3.75	3.75	3.6
High saturation	20.5	20.9 <sup>(2)</sup>	20.5	20.5
Low saturation <sup>(1)</sup>	3.7 <sup>(3)</sup>	3.9	3.9	3.8

(1) Requires 0.1 mA gap between low alarm and low saturation values.

(2) Rail mount transmitters have a high saturation max of 0.1 mA less than the high alarm setting, with a max value of 0.1 mA less than the high alarm max.

(3) Rail mount transmitters have a low saturation min of 0.1 mA greater than the low alarm setting, with a minimum of 0.1 mA greater than the low alarm min.

### Custom alarm and saturation level

Custom factory configuration of alarm and saturation level is available with option code C1 for valid values. These values can also be configured in the field using a Field Communicator.

### Turn-on time

Performance within specifications in less than six seconds after power is applied, when damping value is set to zero seconds.

## Standard accuracy

**Table 16: Rosemount 644 Transmitter Accuracy**

Sensor options	Sensor reference	Input ranges		Minimum span <sup>(1)</sup>		Digital accuracy <sup>(2)</sup>		D/A accuracy <sup>(3)(4)</sup>
		°C	°F	°C	°F	°C	°F	
Pt 100 (α = 0.00385)	IEC 751	-200 to 850	-328 to 1562	10	18	± 0.1	± 0.18	± 0.03% of span
Pt 200 (α = 0.00385)	IEC 751	-200 to 850	-328 to 1562	10	18	± 0.15	± 0.27	± 0.03% of span
Pt 500 (α = 0.00385)	IEC 751	-200 to 850	-328 to 1562	10	18	± 0.19	± 0.34	± 0.03% of span

**Table 16: Rosemount 644 Transmitter Accuracy (continued)**

Pt 1000 ( $\alpha = 0.00385$ )	IEC 751	-200 to 300	-328 to 572	10	18	$\pm 0.19$	$\pm 0.34$	$\pm 0.03\%$ of span
Pt 100 ( $\alpha = 0.003916$ )	JIS 1604	-200 to 645	-328 to 1193	10	18	$\pm 0.1$	$\pm 0.18$	$\pm 0.03\%$ of span
Pt 200 ( $\alpha = 0.003916$ )	JIS 1604	-200 to 645	-328 to 1193	10	18	$\pm 0.27$	$\pm 0.49$	$\pm 0.03\%$ of span
Ni 120	Edison Curve No. 7	-70 to 300	-94 to 572	10	18	$\pm 0.15$	$\pm 0.27$	$\pm 0.03\%$ of span
Cu 10	Edison Copper Winding No. 15	-50 to 250	-58 to 482	10	18	$\pm 1.40$	$\pm 2.52$	$\pm 0.03\%$ of span
Pt 50 ( $\alpha=0.00391$ )	GOST 6651-94	-200 to 550	-328 to 1022	10	18	$\pm 0.30$	$\pm 0.54$	$\pm 0.03\%$ of span
Pt 100 ( $\alpha=0.00391$ )	GOST 6651-94	-200 to 550	-328 to 1022	10	18	$\pm 0.1$	$\pm 0.18$	$\pm 0.03\%$ of span
Cu 50 ( $\alpha=0.00426$ )	GOST 6651-94	-50 to 200	-58 to 392	10	18	$\pm 1.34$	$\pm 2.41$	$\pm 0.03\%$ of span
Cu 50 ( $\alpha=0.00428$ )	GOST 6651-94	-185 to 200	-301 to 392	10	18	$\pm 1.34$	$\pm 2.41$	$\pm 0.03\%$ of span
Cu 100 ( $\alpha=0.00426$ )	GOST 6651-94	-50 to 200	-58 to 392	10	18	$\pm 0.67$	$\pm 1.20$	$\pm 0.03\%$ of span
Cu 100 ( $\alpha=0.00428$ )	GOST 6651-94	-185 to 200	-301 to 392	10	18	$\pm 0.67$	$\pm 1.20$	$\pm 0.03\%$ of span
<b>Thermocouples <sup>(5)</sup></b>								
Type B <sup>(6)</sup>	NIST Monograph 175, IEC 584	100 to 1820	212 to 3308	25	45	$\pm 0.77$	$\pm 1.39$	$\pm 0.03\%$ of span
Type E	NIST Monograph 175, IEC 584	-200 to 1000	-328 to 1832	25	45	$\pm 0.20$	$\pm 0.36$	$\pm 0.03\%$ of span
Type J	NIST Monograph 175, IEC 584	-180 to 760	-292 to 1400	25	45	$\pm 0.35$	$\pm 0.63$	$\pm 0.03\%$ of span
Type K <sup>(7)</sup>	NIST Monograph 175, IEC 584	-180 to 1372	-292 to 2501	25	45	$\pm 0.50$	$\pm 0.90$	$\pm 0.03\%$ of span
Type N	NIST Monograph 175, IEC 584	-200 to 1300	-328 to 2372	25	45	$\pm 0.50$	$\pm 0.90$	$\pm 0.03\%$ of span
Type R	NIST Monograph 175, IEC 584	0 to 1768	32 to 3214	25	45	$\pm 0.75$	$\pm 1.35$	$\pm 0.03\%$ of span
Type S	NIST Monograph 175, IEC 584	0 to 1768	32 to 3214	25	45	$\pm 0.70$	$\pm 1.26$	$\pm 0.03\%$ of span
Type T	NIST Monograph 175, IEC 584	-200 to 400	-328 to 752	25	45	$\pm 0.35$	$\pm 0.63$	$\pm 0.03\%$ of span
Type L	DIN 43710	-200 to 900	-328 to 1652	25	45	$\pm 0.35$	$\pm 0.63$	$\pm 0.03\%$ of span
Type U	DIN 43710	-200 to 600	-328 to 1112	25	45	$\pm 0.35$	$\pm 0.63$	$\pm 0.03\%$ of span

**Table 16: Rosemount 644 Transmitter Accuracy (continued)**

Type C	W5Re/W26Re ASTM E 988-96	0 to 2000	32 to 3632	25	45	± 0.70	± 1.26	± 0.03% of span
Type L	GOST R 8.585-2001	-200 to 800	-392 to 1472	25	45	± 0.25	± 0.45	± 0.03% of span
<b>Other input types</b>								
Millivolt input		-10 to 100 mV		3 mV		± 0.015 mV		± 0.03% of span
2-, 3-, 4-wire Ohm input		0 to 2000 ohms		20 ohm		± 0.45 ohm		± 0.03% of span

- (1) No minimum or maximum span restrictions within the input ranges. Recommended minimum span will hold noise within accuracy specification with damping at zero seconds.
- (2) Digital accuracy: Digital output can be accessed by the Field Communicator.
- (3) Total analog accuracy is the sum of digital and D/A accuracies.
- (4) Applies to HART®/4–20 mA devices.
- (5) Total digital accuracy for thermocouple measurement: sum of digital accuracy +0.25 °C (0.45 °F) (cold junction accuracy).
- (6) Digital accuracy for NIST Type B is ±3.0 °C (±5.4 °F) from 100 to 300 °C (212 to 572 °F).
- (7) Digital accuracy for NIST Type K is ±0.7 °C (±1.3 °F) from -180 to -90 °C (-292 to -130 °F).

**Accuracy example (HART devices)**

When using a Pt 100 ( $\alpha = 0.00385$ ) sensor input with 0 to 100 °C span:

- Digital accuracy = ± 0.1 °C
- D/A accuracy = ± 0.1 °C of 100 °C or ± 0.1 °C
- Total accuracy = ± 0.13 °C

**Accuracy example (FOUNDATION™ Fieldbus and PROFIBUS® PA devices)**

When using a Pt 100 ( $\alpha = 0.00385$ ) sensor input:

- Total accuracy = ±0.15 °C
- No D/A accuracy effects apply.

**Table 17: Ambient Temperature Effect**

Sensor options	Sensor reference	Input range (°C)	Temperature effects per 1.0 °C (1.8 °F) change in ambient temperature <sup>(1)(2)(3)</sup>	Range	D/A effect <sup>(4)</sup>
<b>2-, 3-, 4-wire RTDs</b>					
Pt 100 ( $\alpha = 0.00385$ )	IEC 751	-200 to 850	0.003 °C (0.0054 °F)	Entire sensor input range	0.001% of span
Pt 200 ( $\alpha = 0.00385$ )	IEC 751	-200 to 850	0.004 °C (0.0072 °F)	Entire sensor input range	0.001% of span
Pt 500 ( $\alpha = 0.00385$ )	IEC 751	-200 to 850	0.003 °C (0.0054 °F)	Entire sensor input range	0.001% of span
Pt 1000 ( $\alpha = 0.00385$ )	IEC 751	-200 to 300	0.003 °C (0.0054 °F)	Entire sensor input range	0.001% of span

Table 17: Ambient Temperature Effect (*continued*)

Sensor options	Sensor reference	Input range (°C)	Temperature effects per 1.0 °C (1.8 °F) change in ambient temperature <sup>(1)(2)(3)</sup>	Range	D/A effect <sup>(4)</sup>
Pt 100 ( $\alpha = 0.003916$ )	JIS 1604	-200 to 645	0.003 °C (0.0054 °F)	Entire sensor input range	0.001% of span
Pt 200 ( $\alpha = 0.003916$ )	JIS 1604	-200 to 645	0.004 °C (0.0072 °F)	Entire sensor input range	0.001% of span
Ni 120	Edison Curve No. 7	-70 to 300	0.003 °C (0.0054 °F)	Entire sensor input range	0.001% of span
Cu 10	Edison Copper Winding No. 15	-50 to 250	0.03 °C (0.0054 °F)	Entire sensor input range	0.001% of span
Pt 50 ( $\alpha = 0.00391$ )	GOST 6651-94	-200 to 550	0.004 °C (0.0072 °F)	Entire sensor input range	0.001% of span
Pt 100 ( $\alpha = 0.00391$ )	GOST 6651-94	-200 to 550	0.002 °C (0.0036 °F)	Entire sensor input range	0.001% of span
Cu 50 ( $\alpha = 0.00426$ )	GOST 6651-94	-50 to 200	0.008 °C (0.0144 °F)	Entire sensor input range	0.001% of span
Cu 50 ( $\alpha = 0.00428$ )	GOST 6651-94	-185 to 200	0.008 °C (0.0144 °F)	Entire sensor input range	0.001% of span
Cu 100 ( $\alpha = 0.00426$ )	GOST 6651-94	-50 to 200	0.004 °C (0.0072 °F)	Entire sensor input range	0.001% of span
Cu 100 ( $\alpha = 0.00428$ )	GOST 6651-94	-185 to 200	0.004 °C (0.0072 °F)	Entire sensor input range	0.001% of span
<b>Thermocouples</b>					
Type B	NIST Monograph 175, IEC 584	100 to 1820	0.014 °C	$T \geq 1000$ °C	0.001% of span
			0.032 °C - (0.0025% of (T - 300))	$300$ °C $\leq T < 1000$ °C	0.001% of span
			0.054 °C - (0.011% of (T - 100))	$100$ °C $\leq T < 300$ °C	0.001% of span
Type E	NIST Monograph 175, IEC 584	-200 to 1000	0.005 °C + (0.00043% of T)	All	0.001% of span
Type J	NIST Monograph 175, IEC 584	-180 to 760	0.0054 °C + (0.00029% of T)	$T \geq 0$ °C	0.001% of span

Table 17: Ambient Temperature Effect (continued)

Sensor options	Sensor reference	Input range (°C)	Temperature effects per 1.0 °C (1.8 °F) change in ambient temperature <sup>(1)(2)(3)</sup>	Range	D/A effect <sup>(4)</sup>
			0.0054 °C + (0.0025% of absolute value T)	T < 0 °C	0.001% of span
Type K	NIST Monograph 175, IEC 584	-180 to 1372	0.0061 °C + (0.00054% of T)	T ≥ 0 °C	0.001% of span
			0.0061 °C + (0.0025% of absolute value T)	T < 0 °C	0.001% of span
Type N	NIST Monograph 175, IEC 584	-200 to 1300	0.0068 °C + (0.00036% of T)	All	0.001% of span
Type R	NIST Monograph 175, IEC 584	0 to 1768	0.016 °C	T ≥ 200 °C	0.001% of span
			0.023 °C - (0.0036% of T)	T < 200 °C	0.001% of span
Type S	NIST Monograph 175, IEC 584	0 to 1768	0.016 °C	T ≥ 200 °C	0.001% of span
			0.023 °C - (0.0036% of T)	T < 200 °C	0.001% of span
Type T	NIST Monograph 175, IEC 584	-200 to 400	0.0064 °C	T ≥ 0 °C	0.001% of span
			0.0064 °C + (0.0043% of absolute value T)	T < 0 °C	0.001% of span
DIN Type L	DIN 43710	-200 to 900	0.0054 °C + (0.00029% of T)	T ≥ 0 °C	0.001% of span
			0.0054 °C + (0.0025% of absolute value T)	T < 0 °C	0.001% of span
DIN Type U	DIN 43710	-200 to 600	0.0064 °C	T ≥ 0 °C	0.001% of span
			0.0064 °C + (0.0043% of absolute value T)	T < 0 °C	0.001% of span
Type W5Re/W26Re	ASTM E 988-96	0 to 2000	0.016 °C	T ≥ 200 °C	0.001% of span
			0.023 °C - (0.0036% of T)	T < 200 °C	0.001% of span
GOST Type L	GOST R 8.585-2001	-200 to 800	0.007 °C	T ≥ 0 °C	0.001% of span
			0.007 °C + (0.003% of absolute value T)	T < 0 °C	0.001% of span
<b>Other input types</b>					
Millivolt input		-10 to 100 mV	0.0005 mV	Entire sensor input range	0.001% of span
2-, 3-, 4-wire Ohm		0 to 2000 Ω	0.0084 Ω	Entire sensor input range	0.001% of span

(1) Change in ambient is with reference to the calibration temperature of the transmitter 68 °F (20 °C) from factory.

(2) Ambient temperature effect specification valid over minimum temperature span of 50 °F (28 °C).

(3) Ambient temperature effects are tripled for temperature below -40 °C.

(4) Does not apply to FOUNDATION Fieldbus.

#### Temperature effects example (HART devices)

When using a Pt 100 ( $\alpha = 0.00385$ ) sensor input with a 0–100 °C span at 30 °C ambient temperature:

- Digital temperature effects:  $0.003 \text{ °C} \times (30 - 20) = 0.03 \text{ °C}$
- D/A effects:  $[0.001\% \text{ of } 100] \times (30 - 20) = 0.01 \text{ °C}$

- Worst case error: Digital + D/A + Digital Temperature Effects + D/A Effects = 0.1 °C + 0.03 °C + 0.03 °C + 0.01 °C = 0.17 °C

- Total probable error:  $\sqrt{0.1^2 + 0.03^2 + 0.03^2 + 0.01^2}$  = 0.11 °C

**Temperature effects examples (FOUNDATION Fieldbus devices and PROFIBUS PA)**

When using a Pt 100 (α = 0.00385) sensor input at 30 °C span at 30 °C ambient temperature:

- Digital temperature effects: 0.003 °C × (30 – 20) = 0.03 °C
- D/A effects: No D/A effects apply.
- Worst case error: Digital + Digital temperature effects = 0.10 °C + 0.03 °C = 0.13 °C

- Total probable error:  $\sqrt{0.1^2 + 0.03^2}$  = 0.104 °C

**Table 18: Transmitter accuracy when ordered with option code P8**

Sensor options	Sensor reference	Input ranges		Minimum span <sup>(1)</sup>		Digital accuracy <sup>(2)</sup>		D/A accuracy <sup>(3)(4)</sup>
		°C	°F	°C	°F	°C	°F	
2-, 3-, 4-wire RTDs								
Pt 100 (α = 0.00385)	IEC 751	-200 to 850	-328 to 1562	10	18	± 0.08	± 0.14	± 0.02% of span
Pt 200 (α = 0.00385)	IEC 751	-200 to 850	-328 to 1562	10	18	± 0.22	± 0.40	± 0.02% of span
Pt 500 (α = 0.00385)	IEC 751	-200 to 850	-328 to 1562	10	18	± 0.14	± 0.25	± 0.02% of span
Pt 1000 (α = 0.00385)	IEC 751	-200 to 300	-328 to 572	10	18	± 0.10	± 0.18	± 0.02% of span
Pt 100 (α = 0.003916)	JIS 1604	-200 to 645	-328 to 1193	10	18	± 0.08	± 0.14	± 0.02% of span
Pt 200 (α = 0.003916)	JIS 1604	-200 to 645	-328 to 1193	10	18	± 0.22	± 0.40	± 0.02% of span
Ni 120	Edison Curve No. 7	-70 to 300	-94 to 572	10	18	± 0.08	± 0.14	± 0.02% of span
Cu 10	Edison Copper Winding No. 15	-50 to 250	-58 to 482	10	18	± 1.00	± 1.80	± 0.02% of span
Pt 50 (α = 0.00391)	GOST 6651-94	-200 to 550	-328 to 1022	10	18	± 0.20	± 0.36	± 0.02% of span
Pt 100 (α = 0.00391)	GOST 6651-94	-200 to 550	-328 to 1022	10	18	± 0.08	± 0.14	± 0.02% of span
Cu 50 (α = 0.00426)	GOST 6651-94	-50 to 200	-58 to 392	10	18	± 0.20	± 0.36	± 0.02% of span
Cu 50 (α = 0.00428)	GOST 6651-94	-185 to 200	-301 to 392	10	18	± 0.34	± 0.61	± 0.02% of span
Cu 100 (α = 0.00426)	GOST 6651-94	-50 to 200	-58 to 392	10	18	± 0.17	± 0.31	± 0.02% of span
Cu 100 (α = 0.00428)	GOST 6651-94	-185 to 200	-301 to 392	10	18	± 0.17	± 0.31	± 0.02% of span
<b>Thermocouples<sup>(5)</sup></b>								
Type B <sup>(6)</sup>	NIST Monograph 175, IEC 584	100 to 1820	212 to 3308	25	45	± 0.75	± 1.35	± 0.02% of span
Type E	NIST Monograph 175, IEC 584	-200 to 1000	-328 to 1832	25	45	± 0.20	± 0.36	± 0.02% of span
Type J	NIST Monograph 175, IEC 584	-180 to 760	-292 to 1400	25	45	± 0.25	± 0.45	± 0.02% of span
Type K <sup>(7)</sup>	NIST Monograph 175, IEC 584	-180 to 1372	-292 to 2501	25	45	± 0.25	± 0.45	± 0.02% of span

**Table 18: Transmitter accuracy when ordered with option code P8 (continued)**

Type N	NIST Monograph 175, IEC 584	-200 to 1300	-328 to 2372	25	45	± 0.40	± 0.72	± 0.02% of span
Type R	NIST Monograph 175, IEC 584	0 to 1768	32 to 3214	25	45	± 0.60	± 1.08	± 0.02% of span
Type S	NIST Monograph 175, IEC 584	0 to 1768	32 to 3214	25	45	± 0.50	± 0.90	± 0.02% of span
Type T	NIST Monograph 175, IEC 584	-200 to 400	-328 to 752	25	45	± 0.25	± 0.45	± 0.02% of span
DIN Type L	DIN 43710	-200 to 900	-328 to 1652	25	45	± 0.35	± 0.63	± 0.02% of span
DIN Type U	DIN 43710	-200 to 600	-328 to 1112	25	45	± 0.35	± 0.63	± 0.02% of span
Type W5Re/W26Re	ASTM E 988-96	0 to 2000	32 to 3632	25	45	± 0.70	± 1.26	± 0.02% of span
GOST Type L	GOST R 8.585-2001	-200 to 800	-392 to 1472	25	45	± 0.25	± 0.45	± 0.02% of span
<b>Other input types</b>								
Millivolt input		-10 to 100 mV		3 mV		± 0.015 mV		± 0.02% of span
2-, 3-, 4-wire Ohm input		0 to 2000 ohms		20 ohm		± 0.35 ohm		± 0.02% of span

- (1) No minimum or maximum span restrictions within the input ranges. Recommended minimum span will hold noise within accuracy specification with damping at zero seconds.
- (2) Digital accuracy: Digital output can be accessed by the Field Communicator.
- (3) Total Analog accuracy is the sum of digital and D/A accuracies.
- (4) Applies to HART/4-20 mA devices.
- (5) Total digital accuracy for thermocouple measurement: sum of digital accuracy +0.25 °C (0.45 °F) (cold junction accuracy).
- (6) Digital accuracy for NIST Type B is ±3.0 °C (±5.4 °F) from 100 to 300 °C (212 to 572 °F).
- (7) Digital accuracy for NIST Type K is ±0.7 °C (±1.3 °F) from -180 to -90 °C (-292 to -130 °F).

**Reference accuracy example (HART only)**

When using a Pt 100 ( $\alpha = 0.00385$ ) sensor input with a 0 to 100 °C span: Digital Accuracy would be ±0.08 °C, D/A accuracy would be ±0.02% of 100 °C or ±0.02 °C, Total = ±0.1 °C.

**Differential capability exists between any two sensor types (dual-sensor option)**

For all differential configurations, the input range is X to Y where:

- X = Sensor 1 minimum – Sensor 2 maximum
- Y = Sensor 1 maximum – Sensor 2 minimum

# Dimensional drawings

**Figure 5: Rosemount 644H (DIN A Head Mount)**

HART® device shown with captivated screw terminals

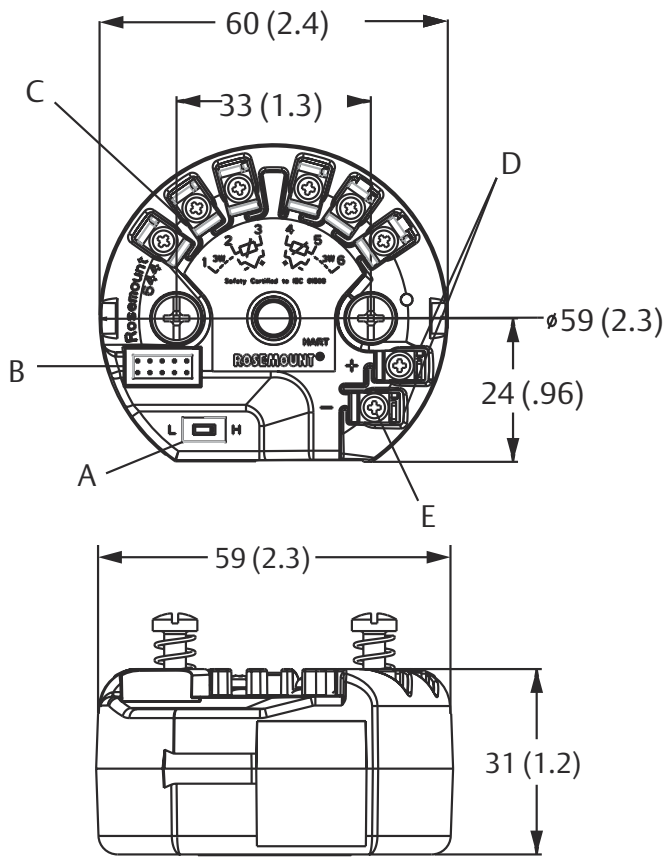

- A. Failure mode switch
- B. Meter connector
- C. Sensor terminals

FOUNDATION Fieldbus and PROFIBUS® device shown with standard compression screw terminals

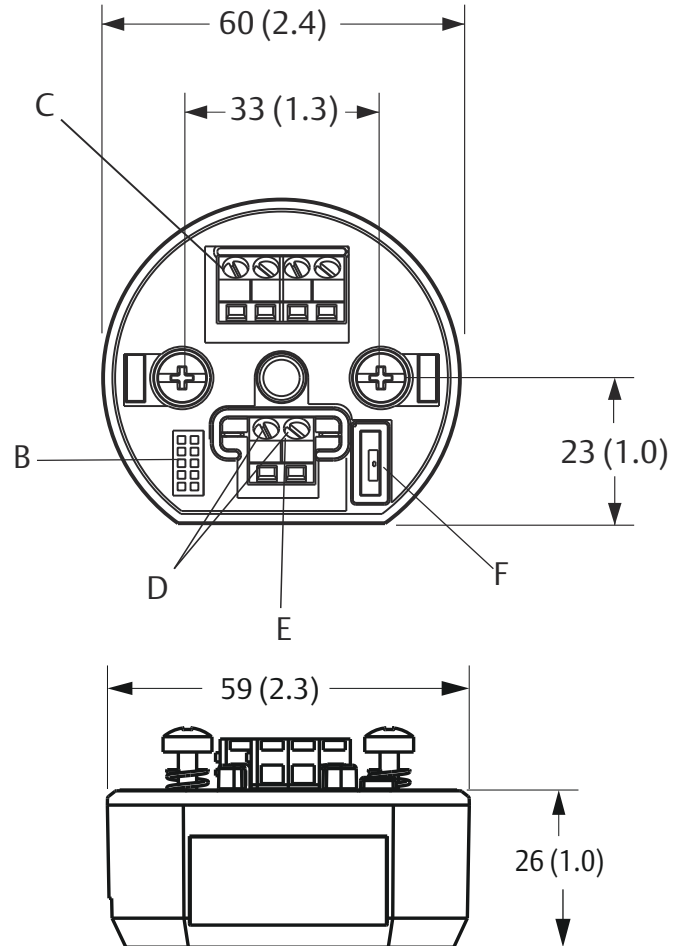

- D. Communication terminals
- E. Power terminals
- F. Simulation switch

**Note**  
Dimensions are in millimeters (inches).

Figure 6: Rosemount 644 Field Mount

Transmitter exploded view

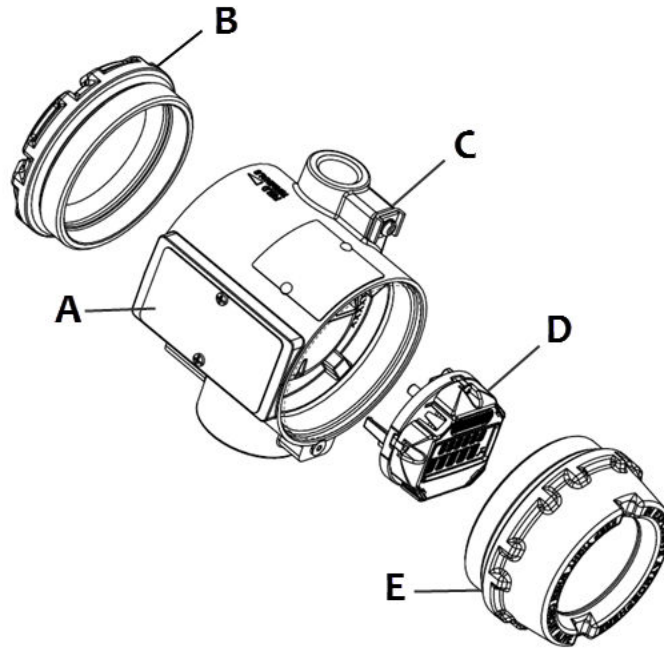

Display compartment

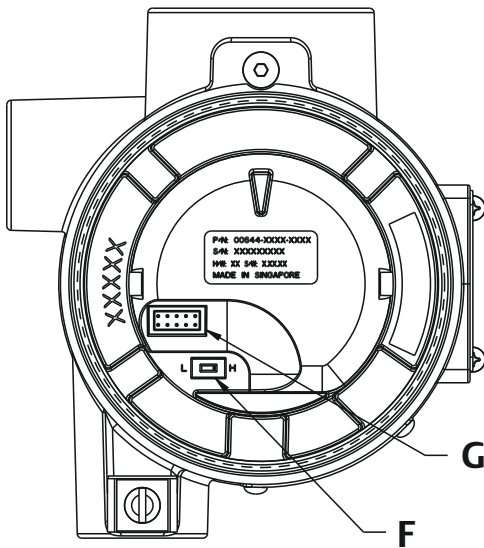

Terminal compartment

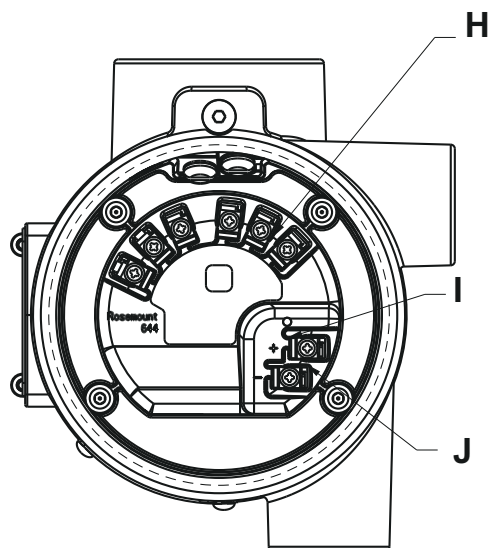

- A. Nameplate
- B. Cover
- C. Housing with electronics module
- D. LCD display
- E. Display cover

- F. Failure mode switch
- G. Meter connector
- H. Sensor terminals
- I. Communication terminals
- J. Power terminals

---

**Note**

Dimensions are in millimeters (inches).

---

**Figure 7: Mounting kits for Rosemount 644H**

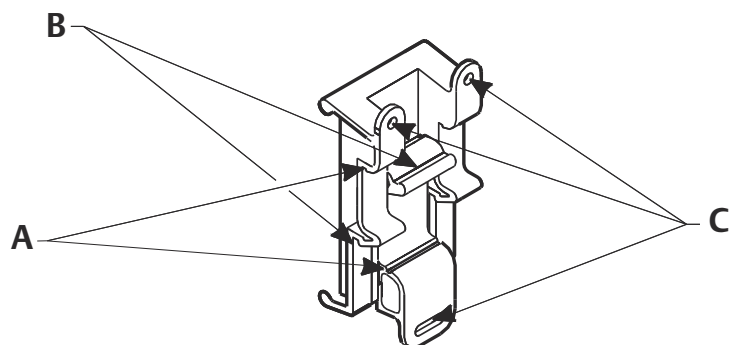

- A. *Top hat rail grooves*
- B. *G-rail grooves*
- C. *Screw holes for mounting to a wall*

Figure 8: Rosemount 644H Rail Clips

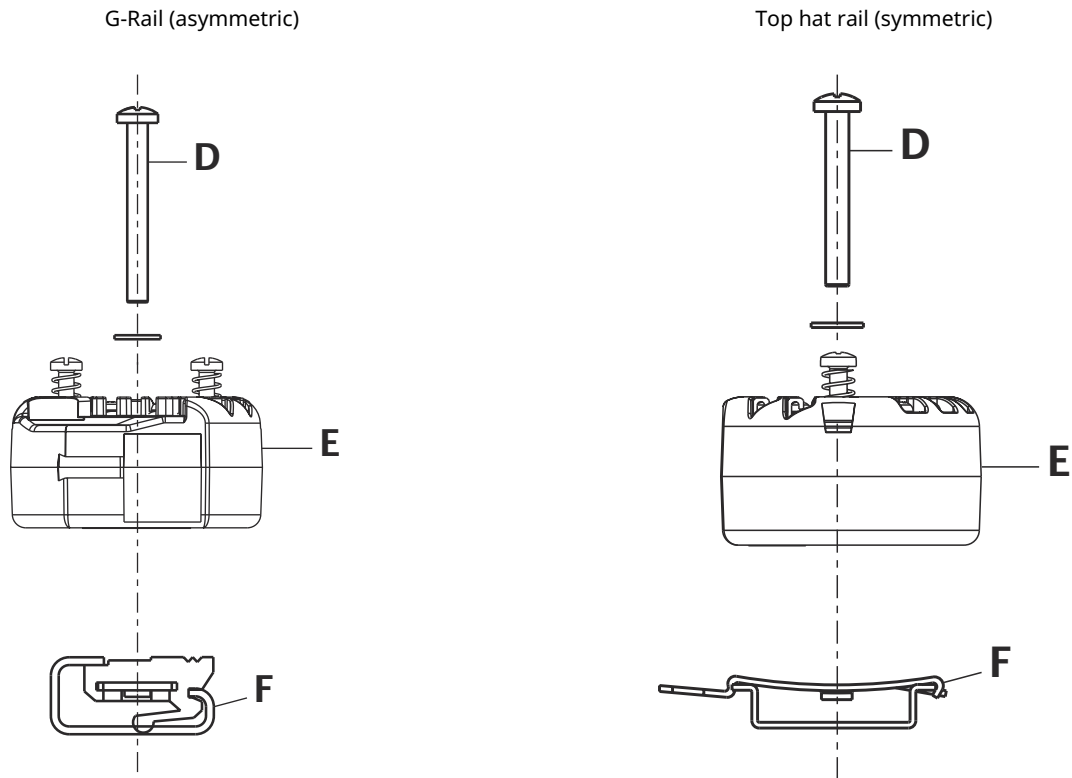

- D. Mounting hardware
- E. Transmitter
- F. Rail clip

**Note**  
Kit (part number 00644-5301-0010) includes mounting hardware and both types of rail kits.

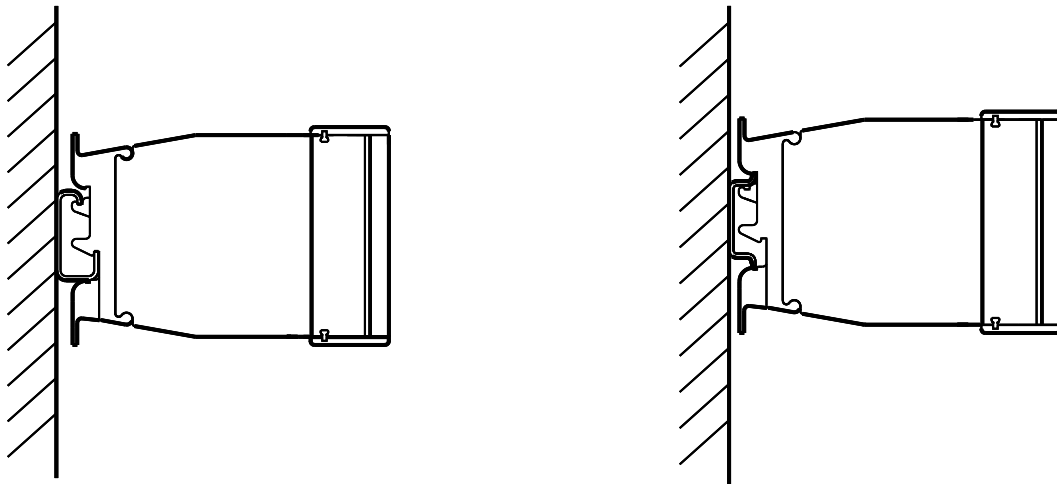

**Note**  
Part number 03044-4103-0001.

Figure 9: Threaded-Sensor Universal Head and DIN Style Sensor Connection Head

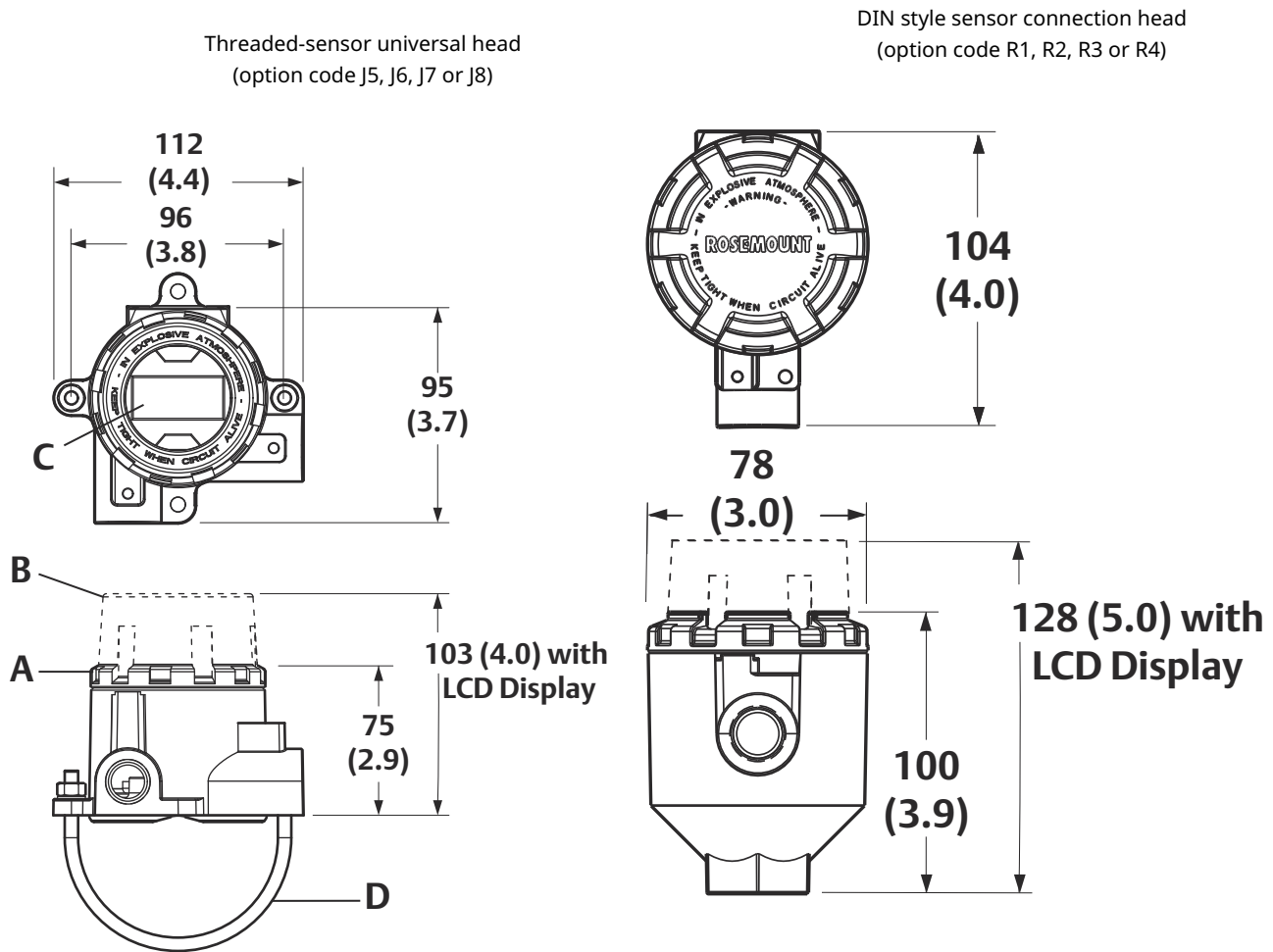

- A. Standard cover
- B. Display cover
- C. LCD display
- D. SST "U" Bolt Mounting, 2-in. pipe (shipped with connection heads J5-J8 when ordered without assembly option XA)

**Note**  
Dimensions are in millimeters (inches).

Figure 10: Threaded Sensor Universal Head, 3-conduit (Option code J1 or J2)

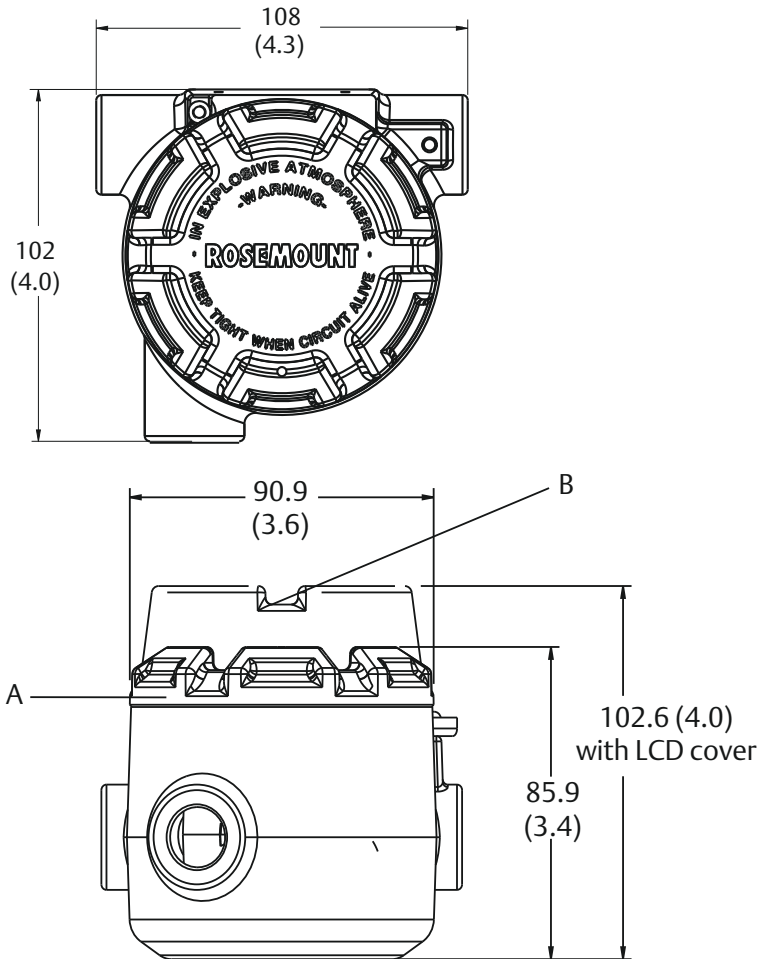

- A. Standard cover
- B. Display cover

**Note**  
Dimensions are in millimeters (inches).

**Figure 11: Device shown with Transient Protector**

HART® device shown with transient protector (Option code T1)

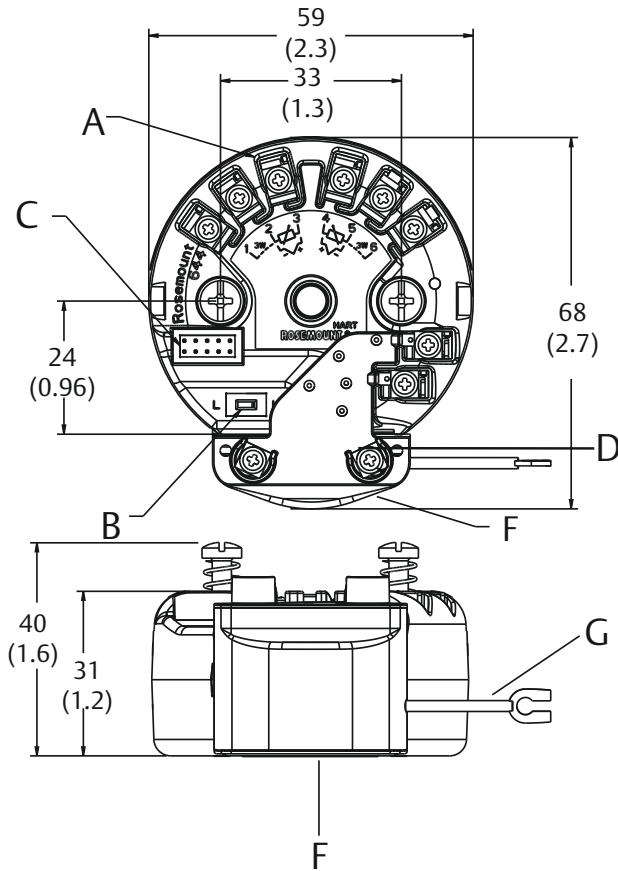

FOUNDATION Fieldbus device shown with transient protector (Option code T1)

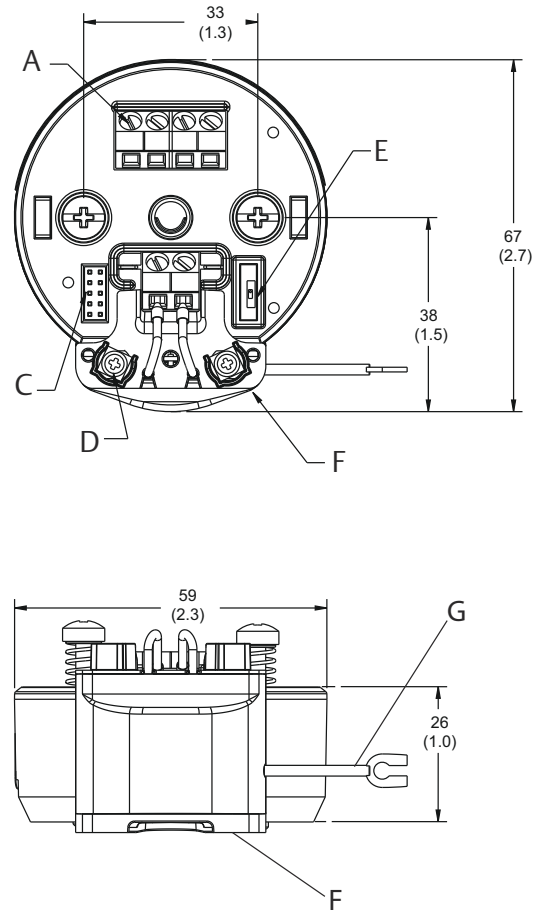

- A. Sensor terminals
- B. Failure mode switch
- C. Meter connector
- D. Power terminals
- E. Simulation switch
- F. Transient protector
- G. Ground wire

**Note**

Dimensions are in millimeters (inches).  
 Option code T1 requires the use of [J1, J2, J3 or J4 enclosure option](#).

## Accessory dimensional drawings

Figure 12: Stainless Steel Housing for Biotechnology, Pharmaceutical Industries, and Sanitary Applications

Sanitary housing (option code S1, S2, S3, S4)

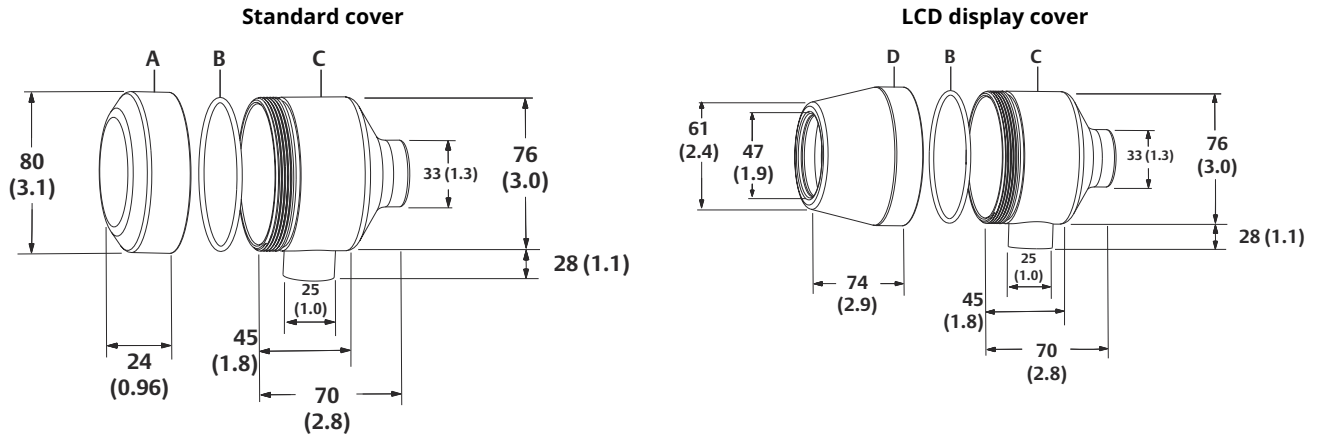

- A. Standard cover
- B. O-ring
- C. Housing
- D. LCD display cover

**Note**

Dimensions are in millimeters (inches).

Figure 13: Display

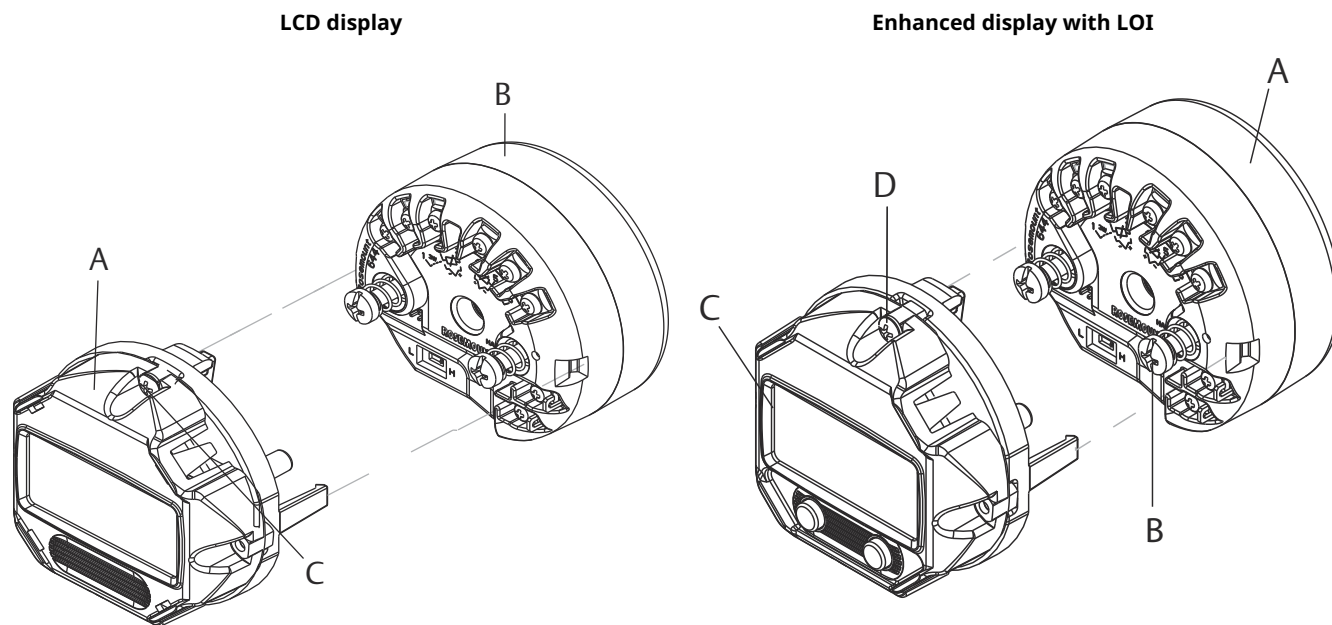

- A. LCD display
- B. Rosemount 644 Transmitter
- C. Display rotation
- D. LCD display with LOI

**Note**

Dimensions are in millimeters (inches).

Figure 14: Optional Mounting

Option Code B4 Bracket for enclosures J1, J2, J3, and J4

Option code B4 bracket for enclosures D1 and D2

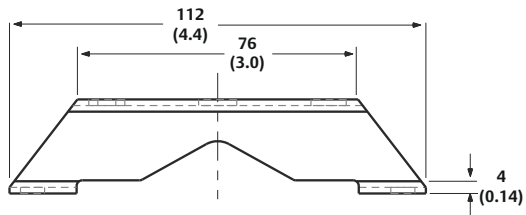
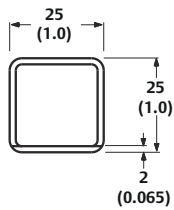
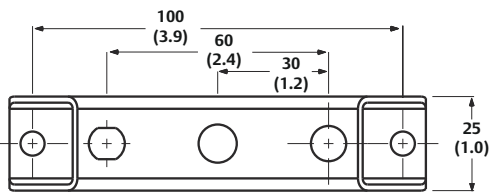
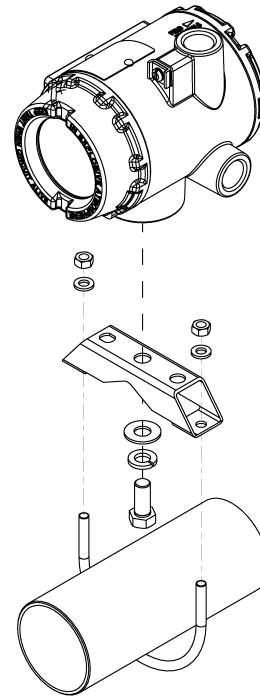
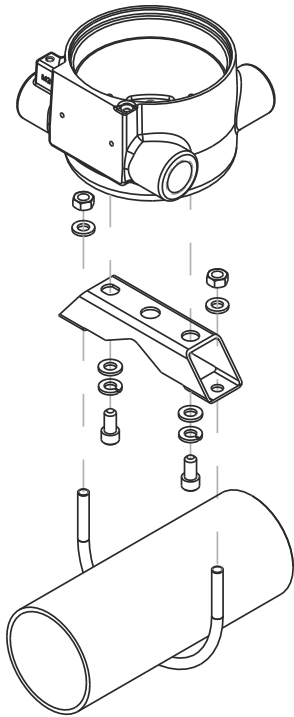

**Note**  
Dimensions are in millimeters (inches).

Option Code B5 Bracket for enclosures J1, J2, J3, and J4

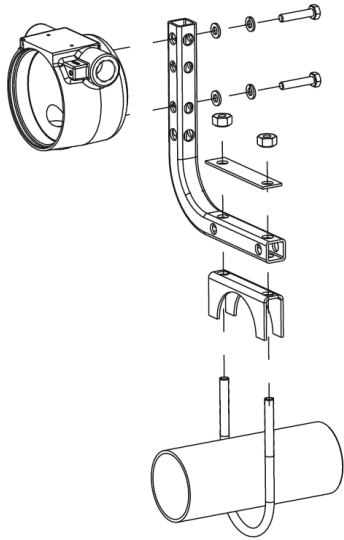

Option code B5 bracket for enclosures D1 and D2

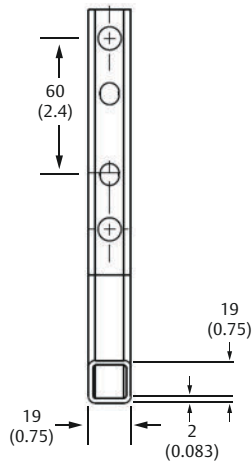
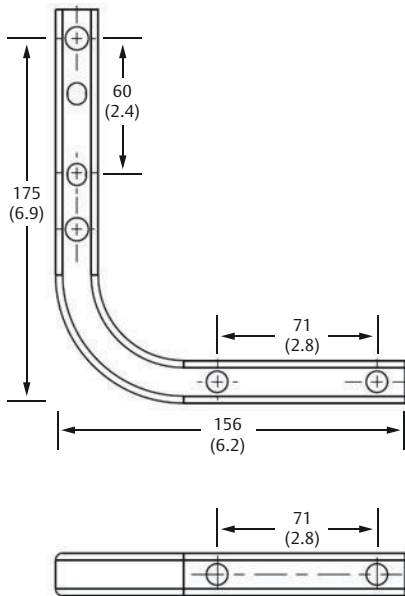
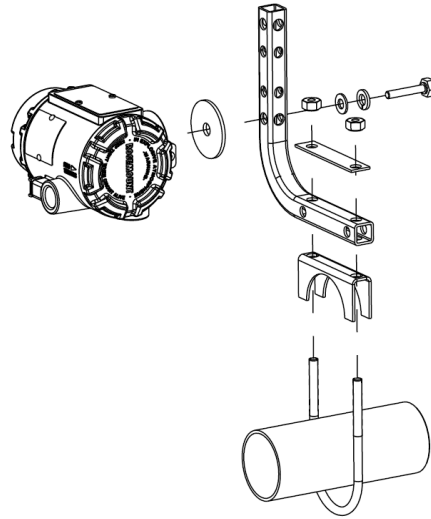

**Note**

Dimensions are in millimeters (inches).

**Configuration**

**Transmitter configuration**

The transmitter is available with standard configuration setting for either HART®, FOUNDATION™ Fieldbus or PROFIBUS® PA. The configuration settings and block configuration may be changed in the field with Emerson DeltaV™, AMS Suite, Field Communicator or other host or configuration tool.

**Table 19: Standard HART® Configuration**

Unless specified, the transmitter will be shipped as follows:

Sensor type	RTD, Pt 100 ( $\alpha=0.00385$ , 4-wire)
4 mA value	0 °C
20 mA value	100 °C
Output	Linear with temperature
Saturation levels	3.9/20.5 mA
Damping	5 seconds
Line voltage filter	50 Hz
Alarm	High (21.75 mA)
LCD display (when installed)	Engineering units and mA
Tag	See <a href="#">Tagging</a> .

**Table 20: Standard FOUNDATION Fieldbus Configuration**

Unless otherwise specified, the transmitter will be shipped as follows:

Sensor type: RTD, Pt 100 ( $\alpha=0.00385$ , 4-wire)
Damping: 5 seconds
Units of measurement: °C
Line voltage filter: 50 Hz
Software tag: See <a href="#">Tagging</a>
Function block tags: <ul style="list-style-type: none"> <li>▪ Resource block: Resource</li> <li>▪ Transducer block: Transducer</li> <li>▪ LCD display block: LCD display</li> <li>▪ Analog input blocks: AI 1300, AI 1400</li> </ul> PID block: PID 1500
Alarm limits of AI 1300, AI 1400 <ul style="list-style-type: none"> <li>▪ HI-HI: Infinity</li> <li>▪ HI: Infinity</li> <li>▪ LO: Infinity</li> <li>▪ LO-LO: Infinity</li> </ul>
Local display (when installed): Engineering units of temperature

Figure 15: Standard Block Configuration

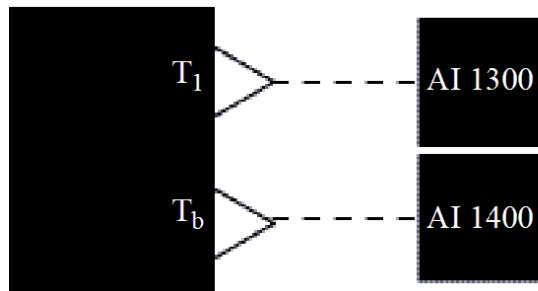

- $T_1$ = sensor temperature
- $T_b$ = terminal temperature

**Final stations**

AI blocks are scheduled for one second. AI blocks are linked as shown in [Figure 15](#).

**Table 21: Standard PROFIBUS® PA configuration**

Unless specified, the transmitter will be shipped as follows:

Device address: 126
Sensor Type: RTD, Pt 100 ( $\alpha=0.00385$ , 4-wire)
Damping: 5 seconds
Units of measurement: °C
Line voltage filter: 50 Hz
Software tag: see <a href="#">Tagging</a> .
Alarm limits: <ul style="list-style-type: none"> <li>■ HI-HI: Infinity</li> <li>■ HI: Infinity</li> <li>■ LO: - Infinity</li> <li>■ LO-LO: Infinity</li> </ul>
Local display (when installed): Engineering units of temperature

**Custom configuration**

Custom configurations are to be specified when ordering. This configuration must be the same for all sensors. The table lists the necessary requirements to specify a custom configuration:

**Table 22: HART® Protocol**

Option code	Customization available
C1: Factory Configuration Data (CDS required)	<ul style="list-style-type: none"> <li>▪ Date: day/month/year</li> <li>▪ Descriptor: 8 alphanumeric characters</li> <li>▪ Message: 32 alphanumeric characters</li> <li>▪ Hardware tag: 18 characters</li> <li>▪ Software tag: 8 characters</li> <li>▪ Sensor type and connection</li> <li>▪ Measurement range and units</li> <li>▪ Damping value</li> <li>▪ Failure mode: High or Low</li> <li>▪ Hot Backup: Mode and PV</li> <li>▪ Sensor drift alert: Mode, limit and units</li> </ul>
...M4 or M5	<ul style="list-style-type: none"> <li>▪ Display configuration: Select what will be shown on the LCD display.</li> </ul>
...DC, A1, CN, or C8	<ul style="list-style-type: none"> <li>▪ Custom alarm and saturation levels: Choose custom High and Low alarm and saturation levels.</li> </ul>
...DC	<ul style="list-style-type: none"> <li>▪ Security information: Write protection, HART® Lock and LOI password</li> </ul>
C2: Transmitter – sensor matching	<ul style="list-style-type: none"> <li>▪ The transmitters are designed to accept Callendar-Van Dusen constants from a calibrated RTD. Using these constants, the transmitter generates a custom curve to match the sensor-specific curve. Specify a Rosemount RTD sensor model on the order with a special characterization curve (V or X8Q4 option). These constants will be programmed into the transmitter with this option.</li> </ul>
A1, CN, or C8: Alarm level configuration	<ul style="list-style-type: none"> <li>▪ A1: NAMUR Alarm and saturation levels, with high alarm configured</li> <li>▪ CN: NAMUR Alarm and saturation levels, with low alarm configured</li> <li>▪ C8: Low alarm (standard Rosemount alarm and saturation values)</li> </ul>
Q4: Three-point calibration with certificate	<ul style="list-style-type: none"> <li>▪ Calibration certificate. Three-point calibration at 0, 50, and 100% with certificate.</li> </ul>
C4: Five-point calibration	<ul style="list-style-type: none"> <li>▪ Will include five-point calibration at 0, 25, 50, 75, and 100% analog and digital output points. Use with Calibration Certificate Q4.</li> </ul>
HR7: HART Revision configuration	<ul style="list-style-type: none"> <li>▪ Your Rosemount 644 head mount and field mount are HART revision selectable. Order the HR7 code to configure your device to operate in HART Revision 7 mode. Your device is also configurable in the field. Refer to the Rosemount 644 Quick Start Guide or Reference Manual for more instructions.</li> <li>▪ Long software tag: 32 characters</li> </ul>

**Table 23: FOUNDATION Fieldbus Protocol**

Option code	Requirements/specification
C1: Factory configuration data (CDS required)	Date: day/month/year Descriptor: 16 alphanumeric characters Message: 32 alphanumeric characters
C2: Transmitter – sensor matching	The transmitters are designed to accept Callendar-Van Dusen constants from a calibrated RTD. Using these constants, the transmitter generates a custom curve to match the sensor-specific curve. Specify a Series 65, 65, or 78 RTD sensor on the order with a special characterization curve (V or X8Q4 option). These constants will be programmed into the transmitter with this option.

**Table 23: FOUNDATION Fieldbus Protocol (continued)**

Option code	Requirements/specification
C4: Five-point calibration	Will include five-point calibration at 0, 25, 50, 75, and 100% analog and digital output points. Use with Calibration Certificate Q4.
Q4: Three-point calibration with certificate	Calibration certificate. Three-point calibration with certificate.

**Table 24: PROFIBUS® PA**

Option code	Requirements/specification
C1: Factory Configuration Data (CDS required)	Date: day/month/year Descriptor: 16 alphanumeric characters Message: 32 alphanumeric characters
C2: Transmitter – Sensor Matching	The transmitters are designed to accept Callendar-Van Dusen constants from a calibrated RTD. Using these constants, the transmitter generates a custom curve to match the sensor-specific curve. Specify a Series 65, or 78 RTD sensor on the order with a special characterization curve (V or X8Q4 option). These constants will be programmed into the transmitter with this option.
C4: Five-point calibration	Will include five-point calibration at 0, 25, 50, 75, and 100% analog and digital output points. Use with Calibration Certificate Q4.
Q4: Three-point calibration with certificate	Calibration certificate. Three-point calibration with certificate.

## Product certifications

For Rosemount 644 product certifications, see the [Rosemount 644 Temperature Transmitter Quick Start Guide](#).

### European Directive Information

A copy of the EU Declaration of Conformity can be found at the end of the [Quick Start Guide](#). The most recent revision of the EU Declaration of Conformity can be found at [Emerson.com/Rosemount](http://Emerson.com/Rosemount).

### Ordinary Location Certification

As standard, the Rosemount 644 Temperature Transmitter has been examined and tested to determine that the design meets the basic electrical, mechanical, and fire protection requirements by a Nationally Recognized Test Laboratory (NRTL) as accredited by the Federal Occupational Safety and Health Administration (OSHA).

### North America

The US National Electrical Code® (NEC) and the Canadian Electrical Code (CEC) permit the use of Division marked equipment in Zones and Zone marked equipment in Divisions. The markings must be suitable for the area classification, gas, and temperature class. This information is clearly defined in the respective codes.

For more information: [Emerson.com/global](https://emerson.com/global)

©2026 Emerson. All rights reserved.

Emerson Terms and Conditions of Sale are available upon request. The Emerson logo is a trademark and service mark of Emerson Electric Co. Rosemount is a mark of one of the Emerson family of companies. All other marks are the property of their respective owners.

**ROSEMOUNT™**

